



**Technical Manual  
for the  
MWD Solar Cup 2020**

**May 15-17, 2020**

**Lake Skinner**

Presented on November 23, 2019  
MWD Solar Cup Technical Team



# **Table of Contents**

Chapter 1—History and Overview

Chapter 2—System Design

Chapter 3—Design Limits

Chapter 4—Configurations

Chapter 5—Electrical System

Chapter 6—Batteries

Chapter 7—Solar Array

Chapter 8—Hull

Chapter 9—Flotation

Chapter 10—Motor

Chapter 11—Propulsion

Chapter 12—Drive Train

Chapter 13—Steering

Chapter 14—Launching

Chapter 15—Power Management

Chapter 16—Instrumentation

Chapter 17—Strategies

Chapter 18—Technical Reports



# Chapter 1—History

MWD's Solar Cup program was launched in Spring 2002 when a Metropolitan executive, attending a conference in Arizona, saw a solar boat competition in Tempe. Why couldn't Metropolitan sponsor a similar program for Southern California high school students?

Metropolitan's Education Programs unit investigated, and found that a solar boat competition could help promote:

- \* Stewardship of natural resources
- \* Reservoir management
- \* Alternative technologies
- \* Engineering
- \* Physics
- \* Environmental Science
- \* Careers in the water industry

Eight schools participated in the first program, 2003. In that inaugural year, Metropolitan worked with a nationally known solar boat competitions consultant, and used their name—Solar Splash. Positive feedback from program participants was tremendous, and Metropolitan's board of directors urged us to continue, and expand the program.

Changing the program's name to Solar Cup in 2004, Metropolitan staff assumed complete program management. Participation nearly tripled, jumping to 22 teams. Media coverage and word of mouth popularized the program even further, and 28 schools participated in 2005. In 2008 we had 41 teams participate in the three-day event. In 2009 we had 33 teams participate in the three-day event.

This year, 2020, the 18<sup>th</sup> year of Solar Cup, we are pleased to have 36 teams participating, and look forward to seeing all 36 participating in the three-day event—May 15-17, at Lake Skinner this spring.



## Chapter 2—System Design

The basic concept of system design is foreign to most of us. It is not a term we used in everyday life. One might define it as: “a consideration of all components and their interaction”.

The concept can be easily understood if we use a bicycle as an example. If we have a flat tire on a bike, that component needs to be fixed before we can ride it, or before the “system” is complete. The same is true if a pedal is missing. In the case of a bike, we can ride it for a short time without a seat but for practical purposes, a bike is a relatively simple mechanical system, made up of about two-dozen components. If we examine a wheel, we start to increase the list with spokes, nuts, bearings, etc.

For the purpose of this discussion, we are going to define the System as **“those major components, that, when functioning properly and together, form a working Solar Boat”**.

Rather than discuss each separate component, we will group some components together into major subsystems such as: Electrical, Mechanical, and Hydrodynamic. This discussion is intended to focus on the interworkings of these systems.

Even before we understand the details, we know that if we overload a boat, it will eventually tip over because it simply has too much weight in it. We also know that the boat is much easier to paddle if there is only one person in it instead of two or three. So, from the start, we have defined one design parameter we must consider, weight.

Within the electrical system, the motor is a key component. We may consider a motor which seems very suitable or may be readily available, but, as we will learn, if it doesn't match the available power, if its weight is prohibitively high, if it is not within the budget, if mounting will present too many problems, then this particular motor is not suitable because of system considerations.

Let's take it a step further and examine the Endurance event and its motor(s). For this event the sources of power are:

1. Direct solar energy, received in real time for the sun and converted with solar panels to electricity
2. Power from the sun we have received in the same manner but have stored in our two batteries

Now, we realize that the Endurance event is a Time, Rate and Distance problem. Time is 90 minutes, Rate is determined by the performance of our entire system, and Distance will determine our success. This means we want to be like the tortoise and not the hare. We want to go at the most constant speed for the 90 minutes and to use all the available power for that time.

If we choose a motor that is too big, we will not have enough power to run it for the full time. If the prop does not match the RPM of the motor, it will be inefficient and waste power. If the drive system has lots of friction, lots of power will be wasted. So now we can see that weight, power, propulsion are key components, which must be matched for this event.

Now, it gets more complex. For the Sprint, we want to go fast. We may decide that a second motor, giving us twice the power, is the way to go. Weight is less important in the Sprint. We are allowed to change propellers but before we make a final decision, let's not forget that we have now added weight for not just the Sprint but also for the Endurance. We are not allowed to add or remove motor(s) from the boat.

The key thing we start to realize is that every component has some effect on another. We cannot make the decision to use any one part without considering its interaction with the other components, which make up the entire system.

So where do we start?

We must begin by understanding each part of the system and setting realistic goals as to what can be done in the same time that lies ahead. Lofty goals are great, but if they are set unrealistically high, the project may not be completed in time. On the other hand, if we choose a very simplistic approach, there may not be enough challenges to hold interest for the team.

Draw up a time line. Work backwards from the date of the Technical Inspection. Leave time for testing. Don't spend so much time studying the problem that there isn't time for component testing and fabrication.

Form sub-teams. Depending on the number of students initially interested in the project, see who is most interested in the hull, electrical and mechanical systems. If you have enough people, divide the responsibilities further but always have a systems group.

Don't forget the smaller aspects. What do you eventually want the boat to look like? What will the skipper's "cockpit" look like? Will it be easy to operate the boat? You don't need to pick a skipper from the start. Some of the strongest technical people may have too much to do, so, identify where your strengths and weaknesses are in the team and try to recruit others to fill in the weakness areas.

**Talk to Each Other!!!** When all is said and done, if there is not good communication, if team members won't listen, or speak, you really have not formed a group that can truly complete the design of the system.

## Chapter 3—Design Limits

All basic rules for the MWD Solar Cup are defined in the Rules Book. In the interest of time, the rules for 2020 are included in final draft form.

These Rules are supplemented by updates. The updates include clarifications of the rules. They include Technical Team questions and answers. There may also be important information about the event. The sum of all this material is considered the complete rules for Solar Cup.

There are a few rules that define the competitive events that have an effect on your design, so they are addressed here.

- **Inspections**—Several types of inspections must be passed before your team can compete. Electrical, mechanical and safety inspections will be performed. All are conducted to assure conformance with the Rules.
- **Qualifying**—You will perform a 200 meter sprint both for time and to demonstrate your ability to keep the boat in a straight line under full power. You will also run a section of the endurance course to show that in the Endurance configuration, you can properly control the boat. This run will also be timed and be used to decide the seeding for Saturday and Sunday's races.
- **Sprint**—The sprint is conducted over a 200-meter straight-a-way course from a standing start. Several heats will be conducted and you will use your solar arrays, on shore, to recharge the batteries between heats. Two sets of batteries are allowed.
- **Endurance**—The largest number of points is available for this event so it is the most important. From a parade start, you will go as far as possible around a closed course in 90 minutes. Since the course will not exceed two kilometers in length, turns are gradual. But precise steering is very important because all boats will be on the water at the same time during this event.



# Rules of Participation In MWD SOLAR CUP



## **A High School Solar/Electric Boating Competition**

### **Sponsored and Published by:**

The Metropolitan Water District of Southern California  
700 N. Alameda Street, Los Angeles, CA 90012  
Phone: (213) 217-6926 | Fax: (213) 830-4564  
Website: [www.mwdh2o.com](http://www.mwdh2o.com)

**Modified:**

**November 13, 2019**

## 1. Purpose of the MWD Solar Cup

**Solar Cup™** is sponsored by The Metropolitan Water District of Southern California. Teams are entered and sponsored by MWD member agencies and local water utilities.

Solar Cup is an event where high school teams design a boat that runs on solar power. The team boat competes in two races, a sprint event and an endurance event. The different events test teams' ability to design their solar boats for maximum energy efficiency as well as speed. This year's event will be held **May 15-17, 2020** at Lake Skinner in Riverside County.

## 2. Program Administration

- 2.1 **Application of Rules** - The Rules shall apply to the **MWD SOLAR CUP Competition**, hereinafter referred to as the "Event".
- 2.2 **Effective Date of Rules** - The Rules become effective immediately and supersede all previous editions.
- 2.3 **Right to Revise Rules** - MWD reserves the right to revise the Rules at any time by providing the participants notification of revisions in the form of Bulletins, revised editions of the Rules, or announcements at the Event.
- 2.4 **Acceptance of Rules** - All persons or groups selected to participate in the Event are expected to know and accept the Rules. Participation in the Event shall constitute acceptance of them.
- 2.5 **Program Administrator** - The Solar Cup program and Event are administered and coordinated by the Metropolitan Water District of Southern California (MWD). MWD is located at 700 North Alameda Street, Los Angeles, CA 90012. All inquiries should be directed to:

Julie Miller Kalbacher, Solar Cup Coordinator  
Mail: P.O. Box 54153, Los Angeles, CA 90054-0153  
Phone: (213) 217-6738 | E-mail: [jamiller@mwdh2o.com](mailto:jamiller@mwdh2o.com)

- 2.6 **Sponsorship**-The program is conducted under the sponsorship of the Metropolitan Water District of Southern California and its participating member agencies. The following are specific requirements related to sponsorship of a team(s):
  - Rookie teams receive a grant from their sponsoring agency of \$4,000 to outfit their hull. Veteran teams receive a grant from their sponsoring agency of \$2,500 to outfit their hull.
  - Only MWD member agency and retail agencies identification will be allowed on the hull.
  - No additional funds may be spent for items used or needed for the boat. Teams must document and report all expenditures and provide an accounting of all monies expended on their boat.
  - Donated materials, not including solar panels and the motor, along with labor (particularly for work that cannot be done by the students, e.g., machining), are allowed, but must be fully documented. **Again, solar panels and the motor must be purchased with sponsorship grant funds only.**
  - **Solar Cup teams may borrow equipment from other Solar Cup teams. Please document all borrowed equipment.**
  - Prior to the event, outside money may be raised for items not related to the boat, such as for a trailer or truck rental to transport the boat to events. Other non-boat items may include, but are not limited to—food for meetings or work days and team apparel.

- 2.7 **Accidents** - All accidents must be reported to an Event official immediately. Failure to do so may affect a Team's standing in the Event. MWD assumes no liability for accidents that occur as the result of poor craft design and construction, unsafe or improper boating procedures, or any form of negligence on the part of the competitors and spectators.
- 2.8 **Parent/Guardian Release and Waiver of Liability for *Solar cup Event***- Every adult and student participant must have the medical and liability release form **signed by a parent or guardian (if under 18 years of age) and turned into MWD by **March 26, 2020**.**
- 2.9 **“Statement of Swimming Ability” for Skippers** - There is a special form for skippers and anyone who will be out on the water, which must be carefully read and signed by each skipper's respective faculty advisor. See 4.2.2.
- 2.10 **Withdrawals** - Any Team which has agreed to participate shall fulfill its obligations unless excused by MWD. Any Team choosing to withdraw must notify MWD in writing. If a Team chooses to withdraw at the Event, MWD must be notified as soon as possible. Any Team choosing to withdraw must return all unused sponsorship funds to their sponsor and provide a detailed accounting of grant monies already expended on the construction of the Team's boat.

### 3. Definitions

- 3.1 **“Paddock”** - Is the Event area where participants prepare their craft and store their boat and equipment.
- 3.2 **“Staging Area”** - Is the area between the paddock area and the “On-Deck Area”.
- 3.3 **“On-Deck Area”** - Is the area between the staging area and the launching site.
- 3.4 **“Launching Site”** - Is the area which extends 10 meters back from the shoreline and extends outward from the shoreline 15 meters. Access to this area is restricted.
- 3.5 **“System Voltage”** - Is the voltage measured with a VOA meter between the system ground and any point in the electrical system.
- 3.6 **“Source Voltage”** - Is the nominal value, e.g., 24 VDC, of the output voltage of the battery pack.
- 3.7 **“Dead-man's Switch”** - Is any device that cuts off power to the motor if the skipper loses control of the craft. This device should be wired to disconnect power to the motor when the switch is shorted. It must be functional at all times when the skipper is in the boat and must be demonstrated in an egress test during Technical Inspection.

### 4. Student Services and Inspections

- 4.1 **Student Services Registration** - Each team must be registered and checked in with Student Services prior to participating. Student services will be open from at **8 a.m. to 4 p.m. each day of the event. Participants are to check in and check out at Student Services every day of the event. Teams who fail to check in and/or check out will lose points each day of the event.**
- 4.1.1 **Point of Contact** - One person, preferably the faculty advisor, must be designated as the primary point of contact for the team during the Event.
- 4.1.2 **Faculty and Guests** - The number of faculty at the Event is not limited. Alumni, family, and friends are all welcome, but may not be team members for insurance purposes.

- 4.1.3 Ballast** - The official skipper weight for the competitive events shall be sixty (60) kg. Each skipper will be weighed when he or she registers. Skippers will be weighed in their bathing suits and life jackets only. If a skipper's weight, including life jacket, is less than 60 kg., ballast will be added to make up the difference. If the weight of the skipper is over 60 kg., no credit will be given. Skipper, life jacket, and ballast will be identified with unique tags. The ballast corresponding to the skipper must be carried in the boat when it is on the water. See Rule 7.2.6 for total weight limitations of skipper and boat.
- 4.2 Technical Inspections** - All craft will be inspected to verify compliance with the Rules. Technical Inspections will begin two weeks prior to the event on **May 2, 2020**.
- **Each team will have to present visual evidence to MWD that their boat has been operational on a body of water in a safe, seaworthy condition by the May 2, 2020 Technical Inspection.**
  - Each craft must also pass technical inspection prior to each race at the Event.
  - Event primary technical inspections will begin at **8 a.m., Friday, May 15, 2020**, and will end at **1 p.m.**
  - Any Team not passing Technical Inspections will be required to correct the deficiency prior to 1 p.m. and be re-inspected before proceeding to Qualifying.
  - Any craft not in compliance with the Rules will not be allowed to compete until it has passed Technical Inspections and Qualifying has been completed.
  - Crafts that do not pass qualifying will not be able to participate in the racing.
  - Craft will be weighed during Technical Inspections.
  - **Any changes made after Inspection require re-inspection.**
- 4.2.1 Safety** - Each team is responsible for the seaworthiness of their craft. Passing Technical Inspections does not relieve the Team of any liability. All craft must be maintained in a safe, seaworthy condition at all times. **Visual proof must be supplied to MWD by May 2, 2020 that the boat was operational in a safe, seaworthy condition.** (rule 4.2) All craft will also have to follow the guidelines supplied by MWD for the prevention of quagga mussel contamination.
- 4.2.2 Swimming Ability** - Technical Inspections on **May 2, 2020** will include a brief test (50m or less and treading water for 1 minute) of the swimming ability of skippers and any other team members who may skipper the craft. Participants will not be allowed to use any flotation equipment or any propulsion device such as "flippers" to assist them. There will be no other means of proving swimming ability.
- 4.2.3 Configuration** - All entries (referred to as boats or craft) must conform to the following definitions. The boat will have a skipper who will be the sole occupant. There will be two configurations of the boat, based on the same hull (fixed structure). The hull is that portion of the boat which provides flotation and stability. The hull must be used as built at the boat-building workshop and must conform to the assembly instructions; exception being the bow of the boat may be rounded and filled so the stem and two sides are even. The fill may not extend the length of boat. It can only be used to even the sides and stem. You may round the top edge of the bulkhead where it meets the boat side; you may not cut the bulkhead down. Gunwales may be rounded slightly. **Additions may be made to the interior but the only allowed removal of material will be holes in the bulkhead for wires; and holes in the hull for the drive train and steering so long as they don't substantially affect the structural integrity of the craft, in the opinion of the judges.** The markings showing a current year hull on the stem, bulkhead and gunwales must be visible to judges and not painted over or disturbed. **In both configurations the skipper, steering, and instruments must be forward of the bulkhead, and the propulsion batteries and drive train must be aft. The master switch must be placed within the reach and visual sight line of the skipper during operation of the craft. The main sitting or kneeling area for the skipper must not be more than 40 inches from the bulkhead. The**

**area will be measured and tested during pre-race inspections. A line will be placed on the outside of the hull as a visual marker to note the 40 inches. Boats that are found to be in violation will be disqualified.**

Solar panels and mounting hardware may not project more than 36 cm beyond the gunwale measured perpendicular.

In the **Endurance configuration**, solar panels must be in place and have a minimum one-sun output of 100 watts and a maximum output of 320 watts. This configuration will be used for Qualifying, including negotiating a fixed-distance obstacle course (maneuverability) in minimum time and an irregular course for a fixed time (Endurance Event).

The **Sprint configuration** is electric only and will be used for a straight line, fixed distance Sprint and a qualifying straight line sprint.

**Motor Configuration:** Boats must use the same motors in either endurance or sprint configuration. Motors may be regared but not removed from or added to the hull.

All craft will be inspected with their solar array or energy conversion devices in place. All components used in any configuration must be inspected along with the craft. All craft will have their configuration verified in the staging area before competing. The Technical Manager may perform inspections at any time at his or her discretion.

- 4.2.4 Solar Array Output - All participants must have their solar collection devices checked to verify that the output does not exceed 320 watts under normal one-sun conditions.

## 5. Entries

- 5.1 **Team Member Eligibility** - Anyone who is currently attending the participating high school as a full-time student is eligible to serve as a team member.
- 5.2 **Skipper Eligibility** - The skipper must be a team member, enrolled in the high school the team represents and must be at least 14 years old.
- 5.3 **Code Of Conduct** – Every person on the team will have a signed Code of Conduct on file with MWD prior to the event. Failure to follow the Code of Conduct will result in dismissal from Solar Cup (**see 11.6**).

## 6. Venue

- 6.1 **Site** - The site for **MWD SOLAR CUP** is Lake Skinner launch ramp 1, approximately 15 miles east of Temecula, California.
- 6.2 **Qualifying** - The course times and dimensions will be laid out as described in section 8, Competition Events. Teams must pass Technical Inspection and both Qualifying courses to participate in Sprint and Endurance events.
- 6.3 **Sprint Course** - The course will be laid out to be logistically convenient. The course will be approximately **200 meters** in length.
- 6.4 **Endurance Course** - The course will be a closed loop, not exceeding 2 km in length, and is likely to be irregular in shape due to the shoreline and spectator areas.

## 7. Regulations

7.1 **Classes** – The entries will compete in two different configurations. Each configuration will have two different categories.

◆ *Solar Endurance*  
--Veteran  
--Rookie

◆ *Sprint*  
--Veteran  
--Rookie

7.1.1 **Solar Endurance** - All craft will be powered by direct and stored solar energy. The maximum output of the solar array under normal one-sun conditions will be 320 watts. The minimum output under normal one-sun conditions is 100 watts. **A maximum of two sets of batteries will be inspected and permitted for use in the Endurance Event.** The craft will be operated only by a skipper at all times, remote control operation is not allowed.

7.1.2 **Sprint** - All craft will be considered “electric” for the Sprint, the solar panel(s) must be removed. **A maximum of two sets of batteries will be inspected and permitted for use in the Sprint Event.** The craft will be operated only by a skipper at all times, remote control operation is not allowed.

### 7.2 **Technical Specifications**

7.2.0 If a boat does not meet any of the technical specifications penalties will be assessed by the event officials.

7.2.1 **Length** - The length of the craft will be approximately 4.6 meters (15 ft, 1 in). **Nothing** may extend forward beyond the bow of the boat. **Only** the boat sign provided at the Event and the rudder may extend beyond the stern of the craft.

7.2.2 **Width** - Nothing may extend more than 36 cm (14.2 in) to the boat center line beyond the deck edge of the craft at any point.

7.2.3 **Height** - The maximum allowable height above the waterline is 1.5 meters (4 ft, 11 in). This height can never be exceeded during the events. This **does not** include the boat number sign.

7.2.4 **Depth** - No restriction. An excessive depth may make the craft awkward to handle near shore and may increase the likelihood of encountering underwater obstacles.

7.2.5 **Cross Sectional Area** - In profile, the fixed area (such as the hull) is unrestricted. The solar array may be fixed or may be in the form of one or more movable panels.

7.2.6 **Weight** - The maximum allowable combined weight for the boat plus skipper and ballast in any configuration is 205 kg (451 lb). Refer to Rule 4.1.4 for additional restrictions on skipper weight. A penalty of 10 points per pound over will be applied, up to max of 15 pounds. (150 points).

7.2.7 All means of generating thrust (propellers, treads, paddles, etc, etc.) must be 100% submerged.

7.2.1 **Materials** - Teams are not allowed to use materials that would pollute the water.

7.3.1 **Shafts** must be constructed from materials of sufficient mechanical and fatigue strength. Hollow shafts are discouraged. If employed hollow shafts must be approved by the technical staff. Hollow shafts should have sufficient wall thickness. Hollow shafts may need to be reinforced at points of contact.

- 7.4 Power** - Sunlight is the only power source that shall be used for propulsion. Wind and human power are not allowed. The sunlight may be direct (received onboard during the Event using photovoltaic panels) or may be stored in approved batteries. Batteries can be charged only from the inspected solar panels, which may not have a one-sun output greater than 320 watts. At no time during the Event may competition batteries be charged with any source other than the approved solar panels.
- 7.4.1 Teams interested in constructing their own solar panels must have designs approved by the Solar Cup Technical Team twice: 1) prior to construction and 2) post construction, prior to utilization. Designs will be evaluated for safety and power generation.**
- 7.4.2 Storage of Solar Radiation** - All craft in the Event will be allowed to store solar energy in their batteries at any time during daylight hours from the time of registration to the completion of the last competition. Battery chargers are NOT to be used on propulsion batteries after they are inspected, but may be used on the supplemental batteries. See 7.4.2(3).
- 7.4.3 Supplemental Batteries (Auxiliary Batteries)** - Supplemental batteries are required for safety reasons. These batteries may not provide propulsion nor directly enhance performance. The bilge pump must be powered by its own supplemental battery. Other acceptable uses include: relays, radio, telemetry, stability control, and memory devices. At Technical Inspection, such batteries and the devices they are in will be checked to assure that no possibility exists to convert the power into propulsion for the craft. The batteries are not limited to lead-acid technology and must be securely fastened to the hull.
- 7.4.4 “System Voltage”** - May not exceed 52 VDC or AC RMS.
- 7.4.5 “Source Voltage”** - May not exceed 24 VDC nominal value (usually 2 batteries). A maximum open circuit voltage of 52 VDC for the photovoltaic charging devices is allowed.
- 7.5 Visibility** - The skipper must have unobstructed vision forward and at least 100° to either side.
- 7.6 Stability** - Due to time constraints, it may be necessary to conduct events in less than ideal conditions. Since safety is vital, the stability of the craft will be tested by placing 10 kg. at the sheer line (outer edge at the beam) with the skipper stationary in the normal operating position. Craft must not heel more than 15°. Skipper must remain centered with hands/feet in normal position.
- 7.7 Throttle** - In all Events, the throttle mechanism on the craft must be free moving and when released, must return to the zero current position. When the throttle returns to the zero position, it must also activate a switch which opens the electrical circuit going to the main motor controller. Additionally, the speed of the boat shall be controlled with a single Curtis PB6 (or similar) manual throttle. There will be no secondary throttle, either in series with, parallel with, replacing or somehow modifying the functionality of the single unmodified Curtis PB6 throttle, which acts as a “cruise control” and allows the motor speed to be regulated independently or in conjunction with the single Curtis PB6 throttle.
- A “**dead-man**” switch must be incorporated in addition to the spring loaded throttle. This “**dead-man**” switch should be wired to disconnect power to the motor controller when the switch is shorted. One does not replace the other, both are required. In addition, a secondary function of the “**dead-man**” switch shall be to short the primary coil of the solenoid to prevent the solenoid from turning on. This switch will be given to all teams at the second technical workshop on 2/1/2020. No substitutions of this switch are allowed.
- 7.8 Ballast Carrier** - The ballast container must be designed in a manner such that the ballast will fall out of the craft if it capsizes (turns over 180°) or adequate flotation must be provided for the ballast.
- 7.9 Automatic Bilge Pump** - An **automatic** electric bilge pump that is powered by a supplemental battery

is required. The pump must have a minimum rating of 500 GPH, such as a model #500 pump made by West Marine or equivalent. The bilge pump must be located aft of the bulkhead, and the discharge hose may not be smaller than the outlet on the pump. The hose must be secured to the hull to ensure that the discharge goes overboard. The battery for the bilge pump must be of sufficient capacity to power the pump for a minimum of two hours and may not be used to power any other devices. The bilge pump shall have a “float switch” to automatically activate the pump when water enters the boat.

**7.10 Covers and Shields** - All steering linkage must be shielded from contact with the skipper. Chain guards must be used wherever there is potential injury to skipper. Skippers whose hair is longer than shoulder length must have it secured in a ponytail or under a hat.

## **7.11 Electrical**

**7.11.1 Shock Hazards** - All exposed conductors operating at greater than thirty-six (36) volts must be properly insulated.

**7.11.2 Battery Type**- Only secondary (electrically rechargeable) batteries are permitted. Fuel cells, primary batteries, or mechanically rechargeable batteries will not be approved. Each team is responsible for supplying its own batteries. The **batteries must be commercially available, lead-acid, unmodified with their weight consistent with the Rules**. Craft are allowed to carry a total battery weight of not more than 25 kg (55 lb). **Batteries must be absolutely stock** (as manufactured) in every sense. The battery modules may not be modified in any manner, including the addition of electrolyte additives, case modification; or plate addition, removal, or modification. **Manufacturer’s data, which includes battery weight and MSDS sheets, must be available at Inspection time.**

**7.11.3 Weighing Batteries** - Batteries will be weighted during Inspection. **MWD scales will be used as the final determination of official total battery weight.** The manufacturer’s data: make and model must be fully specified not just generic battery information that might be in a sales flyer. Batteries that meet the 55 lbs limit will be allowed. Batteries that are specified as 55 lbs or less but weigh up to 57 lbs (a total of 2 lbs over) will incur a penalty of 10 points per pound. Batteries that weigh over 55 lbs and are specified over 55 lbs will not be allowed. Any batteries over a total of 57 lbs, 2 lbs over, will be disallowed even if the manufactures data sheets say they should meet the 55 lbs limit.

After batteries are weighed, a Solar Cup Sticker will be put on the battery top so that it can be easily seen during boat inspections. This sticker is good for the life of the battery, meaning that the battery will not have to be weighed again during subsequent years of competition.

**7.11.4 Battery System** - Batteries must be enclosed in battery boxes and securely anchored to the hull aft of the bulkhead. This must be done in such a manner that the battery boxes and their batteries remain in place if the boat capsizes (see 7.15.2). All electrical cables must be properly sized to expected system currents.

**7.11.5 Motor Switch** - All craft must have a switch wired to disconnect all power to the motor. The switch must be placed within reach and **visual line of sight of the skipper during operation of the craft.** The switch must be able to interrupt full-load current. The switch must have a minimum rating of 310 A continuous, such as the Cole Hersee model M-750.

**7.11.6 Main Fuse** - A separate fuse (not a circuit breaker) must be in series with the main battery connection at all times and the rating must not exceed 350 A.

- 7.11.7 Kill Switch** - A kill switch, or “deadman’s switch”, is a switch that will cut power to the motor in the event of an emergency. Typically, one end of a lanyard is connected to the switch, and the other end is connected to the skipper—either to the skipper’s arm or life vest. **The kill switch is required to cut all power to the motor through the contactor relay when engaged or short circuited.** Refer to circuit diagram in Chapter 5.
- 7.11.8 Contactor Relay** - Contactor relays with the appropriate current rating are required for all boats. The relays must be connected to the deadman switch and serve as direct disconnects to the electrical motor along the high-current line. The contactor relay must be rated for 24 V and continuous duty rating of at least 400 Amps. Example contactor relays include Altrax part # SOL-24V-400A, MZJ-400D or Ametek 24144.
- 7.11.9 Motor Controller**—All boats are required to use motor controllers rated for the amperage greater than the main fuse. All power to the motor must be regulated by a motor controller. The motor controller must not be bypassed.
- 7.12 Radios** - There is no restriction on the type or frequency of voice or telemetry radio communication with the on-shore team and the competition craft but voice radio communications from the Launching Site is required. This will be the responsibility of each Team. **A team member must be in the Headquarters area, with or without a radio, any time their boat is on the water.**
- 7.13 Skipper Cockpit** - The skipper’s cockpit must provide for the skipper’s unassisted exit within 5 seconds in case of emergency. The five (5) second exit, as well as the function of the dead-man’s switch, will be checked during Qualifying.
- 7.13.1 Harnesses** - No harnesses or restraints to hold the skipper in place will be allowed.
- 7.13.2 Safety** - The cockpit area will be inspected for hazards and compliance with the Rules during the Technical Inspections and in the Staging and/or On Deck areas.
- 7.14 Fasteners**
- 7.14.1 Drive Train** - All fasteners associated with the craft’s drive train must be equipped with locking nuts, double nuts, or nuts secured with safety wire or cotter pins. Loctite may be used in areas of difficult accessibility, but must be accompanied by a written statement of application by the Team’s Faculty Advisor.
- 7.14.2 Batteries** – Batteries must be secured to the hull. This must be done with a strap not less than 1¼" in width, or other hold-down device, that will not allow the battery to come loose if the boat capsizes. Velcro is not acceptable.
- 7.14.3 Solar Panels** - Each panel, with or without a frame, must be attached with a mechanical fastening to the hull. The design should take into account the possibility of gusty winds during the events. In addition, a lanyard must be attached from each solar panel to a secure member of the hull or a frame that attaches to the hull. The lanyard must be strong enough that it will not break if the panel should go into the water while the boat is moving.
- 7.14.4 Charge Controllers** - All solar panels will be connected to the batteries through a Solar Charge Controller which regulates the voltage/current flowing into the batteries. The charge controller is required when charging the batteries both in the boat and when charging the batteries off the boat in the paddock area.

## 7.15 Safety Equipment

- 7.15.1 Life Preservers** – A life preserver, USCG approved Type I, II, or III, must be worn by all craft occupants and safety craft occupants at all times.
- 7.15.2 Buoyancy of Craft** - Sufficient flotation must be provided on board so that the craft cannot sink. **Verification calculations must be provided at the Tech Inspection and submitted in writing at every boat inspection.** A 20% safety factor must be included in the calculations.
- 7.15.3 Towing** - A bow eye has been provided to each team and must be used. All boats must carry a minimum of 5 meters of towing line, **which will be provided at the event near the Tech Team area**
- 7.15.4 Signal Devices** - Two signal devices must be carried on board the craft at all times. They are:
- A. Audible** - a sound-producing device (a pressurized air can is acceptable).
  - B. Visual** - an orange (“skier in the water”) warning flag. This flag must be displayed in the event of a breakdown.
- 7.15.5 Paddle** - A paddle, no less than 60 cm long with a blade at least 13 cm wide, must be on board at all times. The skipper will be required to propel the craft with the paddle during Technical Inspections.
- 7.15.6 Fire Extinguisher** - A U.S. Coast Guard approved fire extinguisher with a minimum capacity of one pound must be carried on board.

## 8. Competition Events

- 8.1 Start** – Sprint events will commence from a standing start. Endurance events will commence from a parade start.
- 8.2 Course** - Courses for the on-the-water events are defined as follows:
- 8.2.1 Qualifying** - The primary purpose of Qualifying is to determine the eligibility of Teams to participate in the Event. Teams must pass Technical Inspection prior to attempting to Qualify. Qualifying will be used to test the safety, seaworthiness, handling, and “qualifying time” of each craft. The track of the boat through the two Qualifying courses must generally conform to the courses discussed at **teacher opening meeting on Friday at 8:00 am.** A 200-meter straight line Sprint course will be used and timed to demonstrate the ability of the skipper to control the boat from a standing start in a straight line under full power. A Maneuverability course will use a bouy from the Endurance course that the skipper must pilot the boat the boat around for a complete circle. Failure to complete a Qualifying course disqualifies the team from the event they didn’t pass. If they fail to pass both courses, they cannot continue to participate in on-the-water activities.
- Qualifying Time will be the sum of the times on the Maneuverability and Sprint courses and will be used in determining points towards the overall winner. The time for Qualifying will be used to determine heat position for the Sprint and Endurance Events.
- 8.2.2 Sprints** - Sprints will be held over a 200-meter straight-a-way course. Boats are not allowed to carry their solar arrays during the Sprint event (7.1.3). **Boats will be required to return to the Launching Site without being towed. Paddling is allowed.**
- 8.2.3 Endurance** - The event will be held over a closed course not exceeding 2 km in length. The course will be run in a clockwise direction. All entries must carry their solar panels, as inspected, on board during the Event. Any changes in the solar panels must be re-inspected and re-approved before competing.

- 8.3 Skippers' Meetings** - An open meeting will be held Saturday morning, May 16, and Sunday, May 17, at 7:30 a.m., unless otherwise posted, before the day's events. **Attendance by a skipper or Team leader is mandatory. Failure to do so will result in a penalty which can range from missing a heat to missing the day of racing. A teacher meeting will occur on Friday, May 15 at 8:00 or if the team fails to arrive to site by 8:00 when the team arrives, they should find Julie.**
- 8.4 Overtaking** - Once an overtaking craft establishes overlap (the bow breaks an imaginary perpendicular plane across the stern of the overtaken craft), the overtaking craft has the right-of-way.
- 8.5 Buoys** - The first craft to reach a buoy has the right-of-way until the stern of the craft has cleared the buoy. If a craft strikes a buoy, a penalty will be assessed (see Rule 11).
- 8.6 Leaving the Course** – In the Endurance Event, if a boat leaves the course for any reason, it must re-enter at the same point or further back. During the sprint event, if a boat leaves the course, they may not re-enter the course, they will get a failed attempt. **If the skipper fails to follow the return rules for the sprint race, they will be assessed a penalty of 30 seconds.**
- 8.7 Overnight Impound** - All craft will be impounded overnight on Friday, **May 15** and Saturday, **May 16** in the paddock area to prevent “all-nighters”, which could cause safety concerns. Impound will begin after qualifying on Friday, **May 15**, and will be from 5 p.m. to 7 a.m. daily. **No components may be taken from Lake Skinner Launch Ramp parking lot area.** If a new component is acquired during the impound time, it must be inspected before being installed in the craft.
- 8.8 Support Craft** - No support craft will be allowed.
- 8.9 Scoring and Results** - The results of each day's events will be available no later than the following day's morning meeting. The results of the final day's events will be announced and posted at the final awards ceremony.
- 8.10 Overall Scoring – Total possible points is 1000.** In order to determine an overall MWD Solar Cup Champion, the following overall scoring system is used:

**Technical Reports - 50 points.** Two progress reports will be required at specific dates (see 8.13).

**Outreach Project - 250 total points.** The Public Service Message (PSM) has two parts; the Final Outreach Project (PSM) is worth 220 points and the Outreach Project draft outline worth 30 points. **If a team fails to submit a draft outline, they CANNOT submit a final Outreach Project.** The draft outline must be received at MWD headquarters by 5:00 pm on **February 20, 2020.**

The final Outreach Project will be judged on: Creative use of theme and format; content that is accurate and consistent with the published topic, appeal of design and messages that clearly articulate the theme. The final Outreach Project is due on **April 9, 2020.** **All final PSM's must be sent to MWD via Hightail address detailed in the brochure. Late entries will be penalized 20% or 44 points.**

#### **Outreach Project**

Students will be asked to create a conservation themed piece, see Outreach Project workshop handouts and brochure for specific theme and more details.

#### **Outreach Project Draft Outline**

The written draft (outline) should be no longer than one page, double-spaced in 10 to 12 point font (see 8.12 for the due date). Up to two additional pages with the same format requirements will be accepted as an attachment to the outline to share feedback from your testing or evaluation. It will include highlights of the method for testing, the feedback received and how it was used (if at all) to modify the final product.

### **Outreach Project Scoring**

Scoring will be based on the total points awarded to the project by the review panel. The panel will award points based on how well the project followed the criteria detailed in the Outreach Project Brochure. The points awarded on the draft will be added to the final Outreach Project points for the total points awarded. The project that receives the most points will receive 250 points, the maximum award. Points will descend by two (2) per place. There may be ties. If so, equal points will be awarded.

**Deadlines—55 points.** Each team is asked to meet deadlines throughout the Solar Cup program. Failure to meet deadlines will cause the team to lose points in various categories. Teams are now responsible for submitting the following items on time to earn the points in this new point category:

- Submit the team liability forms by **5 p.m., March 26, 2020 (30 pts)**
- Submit the final boat expenditure sheet by **5 p.m., April 23, 2020 (5 pts)**
- Submit a photo showing boat was on the water and seaworthy by **May 2, 2020 (5 pts)**
- Pass Technical Inspection on **May 2, 2020**. Boat must pass 85% of items on Tech Sheets **(15 pts)**

**Qualifying - 50 points.** Teams that pass Inspection by the posted time and are within the hours posted for Qualifying may be given the opportunity to run the Qualifying courses for score. The times from the two courses will be added. (No practice will be permitted). The fastest qualifier will receive 50 points. All other qualifiers will be scored by the formula:

$$\text{Your points} = \frac{\text{Winner's time}}{\text{Your time}} \times 50$$

If multiple attempts must be made in order to qualify, your qualifying time on that course will be multiplied by the number of attempts to determine your time.

**Sprint - 250 points.** The same formula will be used for the Sprint as is used for Qualifying with the modification that it will be based on the best two times. If a competitor fails to complete either of their first two heats, they will be assigned the time of the slowest competitor in that round +5 seconds.

**Endurance Event - 345 points.** The purpose is to go as far as possible in 1.5 hours. Total distance traveled will be recorded to the nearest .25 lap completed.

$$\text{Your points} = \frac{\text{Your total distance (two heats)}}{\text{Winner's total distance (two heats)}} \times 345$$

- 8.11 Seeding** - All entrants will be seeded for the Sprint based on their sprint qualifying time.
- 8.12** The Outreach Project has two due dates that must be met. **Components will only be accepted up to one week late.**
- Draft Outreach Project is due no later than **5:00 p.m., February 20, 2020**
  - Final Outreach Project is due no later than **5:00 p.m., April 9, 2020** for two items listed below:
    - **Final PSA—must be submitted to MWD via Hightail address detailed in the brochure.**
    - **Outreach Project Team Participation Form (send via email).**
- 8.13 Technical Reports** - Progress reports are due at Metropolitan Water District Headquarters at the times below (see 2.5). A penalty of 5 points will be assessed for any late reports. Reports will only be accepted up to one week late. Reports must be turned in electronically or if too large to send electronically, via cd or dvd.

- Drive Train and Steering Report is due via email no later than **5:00 p.m., January 9, 2020.**
- Solar Array and Electrical System Design Report is due via email no later than **5:00 p.m., February 13, 2020.**

## 9. Graphics

- 9.1 Boat Number Signs** - Each craft will have a “boat number”. Each team will be provided with a base and an “L” bracket for their “boat number” sign. It, or a satisfactory substitute, must be mounted in a manner which will allow for the proper display of the sign. All participants will be provided physically similar signs. These signs and “L” brackets may not be modified. The sign will not be included in the dimensions of the craft.
- 9.2 Event Logo** - The Event identification and logo must be displayed at all times. These are part of the boat number sign. In addition, all materials produced by teams, which use the MWD logo, seal or Solar Cup logo, **must be approved by MWD** before being printed and distributed.
- 9.3 School Name** - School names on the craft are optional, but recommended.
- 9.4 Sponsor Identification** – All boats are must have Metropolitan Water District and their sponsoring MWD Member Agency and retail agency if applicable stickers displayed on each side of the craft, above the waterline, at all times. MWD will furnish sponsor decals in white, black, or blue. No other sponsoring agency or business logos may be displayed on the hull. The participant must provide an area to apply decals of at least 24 inches in length aft of the bow stem and forward of the stern stem. This area will be a solid color that will contrast with the logos provided. (This allows approximately 9’ in the center area on each side for your school name.)
- 9.5 Inappropriate Graphics** - MWD reserves the right to disapprove any graphics.

## 10. Dates and Times

- 10.1 Technical Inspections** – Saturday, **May 2, 2020**, 9:00 a.m. to 3 pm. During the event weekend, Technical Inspection will occur on Friday, **May 15, 2020** from 8:00 a.m. to 1:00 p.m. Re-inspections will take place at the event prior to each race on Saturday and Sunday.
- 10.3 Swim Test** - Saturday, **May 2**, 10 a.m.- 3 p.m.; location to be announced
- 10.4 Qualifying** – Typically held on Friday, **May 15**, 9 a.m. to 4 p.m.; Event site, Lake Skinner
- 10.5 Endurance** – Typically held on Saturday, **May 16**, 10 a.m.; Event site, Lake Skinner
- 10.6 Sprint** – Typically held on Sunday, **May 17**, 10 a.m.; Event site, Lake Skinner
- 10.7 Weather** - The Sprint and Endurance competition days and times are at the discretion of the MWD. Weather conditions may dictate competition days and times.

## 11. Penalties

Any Team failing to comply with the Rules, as stated herein, may be penalized. Officials are required to record all instances of unsafe conduct, and penalties will be assessed as follows:

- 11.0 Failure to Comply with the Regulations** - Officials may assess penalties ranging from ten (10) points to total disqualification for a Team’s failure to comply with any Regulation.

## 11.1 Qualifying

- 11.1.1 Leaving the Course - If a craft leaves the Qualifying course, as defined in Rule 8.2.1, the craft has not qualified.
- 11.1.2 **Striking a buoy** - If a craft strikes a buoy, a ten (10)-second penalty will be assessed.
- 11.1.3 **Failure to pass Technical Inspection** on Friday, **May 15, 2020 by 1:00 p.m** disqualifies teams from further on-the-water events.
- 11.1.4 **Failure to pass Qualifying courses** disqualifies teams from participating in the event that they failed to qualify.

## 11.2 Sprints

- 11.2.1 **Disturbing Official Battery Markings** - When batteries are inspected, they will be given official tags. These markings must not be disturbed. Competitors are allowed to use only the batteries inspected for their craft. Officials may assess penalties ranging from fifty (50) points to total disqualification.
- 11.2.2 **Obstructive Boating** - Any team that operates their craft in a manner that impedes the progress of another craft or risks the safety of another craft or of their own will receive a minimum penalty of fifty (50) points or may be disqualified at the discretion of the officials.
- 11.2.3 **Striking a buoy** - If a craft strikes a buoy and remains in its lane, a five (5) second penalty will be assessed.
- 11.2.4 **Leaving the course** - If a craft leaves its assigned lane, its run has ended and it must be shut down and may not re-enter the course or finish. See 8.10 for scoring.

## 11.3 Endurance

- 11.3.1 **Disturbing Official Battery Markings** - When batteries are inspected, they will be given official tags. These markings must not be disturbed. Competitors are allowed to use only the batteries inspected for their craft. Officials may assess penalties ranging from fifty (50) points to total disqualification.
- 11.3.2 **Obstructive Boating** - Any team that operates their craft in a manner that impedes the progress of another craft or risks the safety of another craft or of their own will receive a minimum penalty of one lap per infraction or may be disqualified at the discretion of the officials.
- 11.3.3 **Striking a buoy** - If a craft strikes a buoy, the craft will be penalized a minimum of .5 laps per infraction.
- 11.3.4 **Failure to Yield to Right-of-Way** - Any Team failing to allow right-of-way when being overtaken by another craft will be penalized a minimum of .5 laps per infraction.
- 11.4 **Paddling** - Using paddles or oars to power the craft during any competitive event (other than to avoid becoming a safety hazard) will result in automatic disqualification.
- 11.5 **Failure to Attend Skippers' Meetings** - Any team that fails to be properly represented at any Skippers' meeting will be penalized in the form of missing a heat or missing the day's race and must receive a briefing before they can continue to compete.

- 11.6 Code of Conduct** - Officials may assess penalties ranging from ten (10) points to total disqualification for improper conduct that does not uphold the spirit and educational intent of Solar Cup. Such conduct may include, but is not limited to, improper or demeaning language, failure to listen to officials during any workshops and/or event (including at campground area) and obscene gestures.

## **12. Advertising, Promotion and Publicity**

All advertising, sales promotion, and publicity material produced by the teams or their sponsors concerning or referring to the Event shall refer to the Event as **MWD SOLAR CUP**. By entering the Event, all teams shall agree to the use of, without compensation, their names and photographs in any publicity material that may be issued by MWD.

## **13. Prizes and Awards**

MWD will recognize all Teams' participation. In addition, the following awards will be presented:

- 13.1 Daily Award** - Daily awards may be presented.
- 13.2 Overall and Runner-Up Awards** - For each competition, an award will be presented to the Team that demonstrates the best performance. Runner-up awards will also be presented. An Overall Winner will be determined by a formula which includes: Progress Reports, PSA, Deadlines, Qualifying, Endurance, and Sprint.
- 13.3 Other Awards** - Other awards may be presented at various times during the Event.
- 13.4 Award Ceremonies** - An awards ceremony will be held on Sunday, **May 17**, following the final competition.

## **14. Procedures**

**To assure that all competitors are in compliance with the Rules during the competitions, an "On-Deck" area has been established. There are some safety concerns that will be checked, and are subject to penalty. This, along with the "Staging" area, is intended to expedite the conduct of the competitions, especially the Sprint events. All Rules and procedures are written with the fairness and safety of the participants and spectators in mind.**

- 14.1** All competitors must be in the "Staging" area at least one hour before the competitions. Charging of the battery pack via the sun may occur during this time.
- 14.2** As boats are moved from the "Staging" area to the "On-Deck" area there will be a brief reinspection. No work can be done on the boats once the boats are in the on deck area.
- 14.3** Only one set of batteries may be used for one Endurance Heat. Batteries can not be changed during the heat.
- 14.4** At no time during qualifying or the competitions will a swimmer be allowed in the water to assist a boat in any manner.
- 14.5** Protective eyewear must be worn at all times by anyone who is handling batteries. Footwear is recommended for all participants.
- 14.6** Should there be a question regarding the meaning of Rules, the participating team will file their question in writing with the Registrar using a Rule Interpretation Form.

## **15. Paddock Area**

This is the area that is under large tents, where each entry will have an area of approximately 20' x 20'. The area is used to work on and store the craft. Participants are encouraged to have school banners or other identification. The area immediately outside the tent may be used for recharging.

## 16. On-The-Water testing

Because of restrictions at the site, no on-the-water testing will be allowed at Lake Skinner during the Event starting at 6 a.m., **Friday, May 15** through **Sunday, May 17, 2020**.

## 17. Amendments

### 17.1 Skeg Rule Amendment

#### Ruling Background:

In the past Solar Cup teams have inquired about the use of a keel, skeg or fin attachment(s) to the bottom of their boats. In this context a keel, skeg or fin attachment(s) is a vertical attachment to the bottom of the boat designed to aid in the directional stability or steering of the boat. **Rule 4.2.3**, see below, was applied to not allow modifications to the hull structure based upon the following specific wording:

*... The hull must be used as built at the boat-building workshop and must conform to the assembly instructions. Additions may be made to the interior but the only allowed removal of material will be holes in the bulkhead for wires; and holes in the hull for the drive train and steering, so long as they don't substantially affect the structural integrity of the craft, in the opinion of the judges.*

Although it is somewhat questionable how significant such a attachment would “aid in the directional stability or steering” of the “6 hour canoe” boat design as compared to a conventional rudder, in keeping with the competition goal of safety it was felt by the MWD and the technical team that if such a structure could aid in the directional stability of the boat some allowance or ruling for such a structure should be made.

#### Current Applicable Rules

**4.2.3 Configuration - All entries (referred to as boats or craft) must conform to the following definitions. The boat will have a skipper who will be the sole occupant. There will be two configurations of the boat, based on the same hull (fixed structure). The hull is that portion of the boat which provides flotation and stability. The hull must be used as built at the boat-building workshop and must conform to the assembly instructions. Additions may be made to the interior but the only allowed removal of material will be holes in the bulkhead for wires; and holes in the hull for the drive train and steering, so long as they don't substantially affect the structural integrity of the craft, in the opinion of the judges.**

#### The ruling:

A skeg, fin or keel, here after referred to as the structure(s), **will be allowed provided it meets the following requirements:**

- a. The structure must be mounted vertical with respect to the bottom of the boat. In this configuration the structure will be **perpendicular to the surface of the water** when the boat is at rest. **No horizontal components such as wings or foils** which attempt to provide lift or thrust to the boat will be allowed as part of the structure.
- b. The maximum **length** of the structure will be **less than 10 inches** measured from the boat hull.
- c. The total square inches of all such attachment(s) will be **limited to 30 square inches in profile** (i.e. from the side view). Because these structures often have unique curvatures<sup>1</sup> it is up to each team to prove that its design is less than the prescribed amount.<sup>2</sup>

---

<sup>1</sup> <http://islandfindesign.com/finstore/templatepage.htm>

<sup>2</sup> The profile or side view area can probably be determined easiest by tracing the profile of the structure onto graph paper, for example ¼ inch or finer and then adding up the amount of square inches contained within the profile.

- d. The number of structure attachments will be limited to a **maximum of three**, however the total square inches of all must be 30 square inches or less, so if three equal size structures are proposed each must be less than 10 square inches.
- e. The structure must be **planar or flat** in nature with the thickest part of the structure attached to the bottom of the boat with the structure tapering as it extends away from the boat. Structures such as a “bulb keel”<sup>3</sup> or “tunnel fin”<sup>4</sup> which dramatically vary the thickness or cross-sectional area of the structure will not be allowed.

Resources used in the development of this ruling were:

MWD Solar Cup Rules

<http://en.wikipedia.org/wiki/Skeg>

[http://en.wikipedia.org/wiki/Surfboard\\_fin](http://en.wikipedia.org/wiki/Surfboard_fin)

Final notes: As a modification to the current rules any team considering the addition of such a structure should contact MWD early in the design process to clarify their design before any construction takes place on their boat.

---

<sup>3</sup> [http://www.lhyb.com/yacht\\_images/tenacious/keel.jpg](http://www.lhyb.com/yacht_images/tenacious/keel.jpg)

<sup>4</sup> See example at <http://www.tactics.com/turbo-tunnel/95-turbo-tunnel-fin>

## 17.2 Battery Amendment

### Rule Advisory

7.11.2 Battery Type- Only secondary (electrically rechargeable) batteries are permitted. Fuel cells, primary batteries, or mechanically rechargeable batteries will not be approved. Each team is responsible for supplying its own batteries. The batteries must be commercially available, lead-acid, unmodified with their weight consistent with the Rules. Craft are allowed to carry a total battery weight of not more than 25 kg (55 lb). Batteries must be absolutely stock (as manufactured) in every sense. The battery modules may not be modified in any manner, including the addition of electrolyte additives, case modification; or plate addition, removal, or modification. Manufacturer's data, which includes battery weight and MSDS sheets, must be available at Inspection time. Batteries will be weighted during Inspection. MWD scales will be used as the final determination of official total battery weight. ***The manufacturer's data: make and model must be fully specified not just generic battery information that might be in a sales flyer. Batteries that meet the 55 lbs limit will be allowed. Batteries that are specified as 55 lbs or less but weigh up to 57 lbs (a total of 2 lbs over) will incur a penalty of 10 points per pound. Batteries that weigh over 55 lbs and are specified over 55 lbs will not be allowed. Any batteries over a total of 57 lbs, 2 lbs over, will be disallowed even if the manufactures data sheets say they should meet the 55 lbs limit.***

## 17.3 Rule clarification on the rudder supporting structure: rules that apply 7.2.1 and 4.2.3

*Rule: 7.2.1 Length - The length of the craft will be approximately 4.6 meters (15 ft, 1 in). Nothing may extend forward beyond the bow of the boat. Only the boat sign and the rudder may extend beyond the stern of the craft.*

*Rule 4.2.3, portion listed below, has been applied to not allow modifications to the hull structure based upon the following wording:*

*... The hull must be used as built at the boat-building workshop and must conform to the assembly instructions. Additions may be made to the interior but the only allowed removal of material will be holes in the bulkhead for wires; and holes in the hull for the drive train and steering, so long as they don't substantially affect the structural integrity of the craft, in the opinion of the judges.*

Because the above two rules are somewhat contradictory and especially because of the difficulty in mounting the rudder supporting structure to the narrow portion of the stern (which must also allow for the boat sign mount) teams which attach anything to the outside of their boats in conjunction with the rudder structure must have the design pre-approved by MWD before the Technical Inspection date **(May 2, 2020)**.

In general, small supporting structures near the gunwale (From Wikipedia: The gunwale, nautical term describing the top edge of the side of a boat.) maybe granted waivers but should be designed such that they will not be in the water during either the sprint or endurance competition. This will most likely limit any rudder supporting structure to within a few inches of the gunwale.

## Chapter 4—Configurations

There are two configurations for the boat that are allowed under the Rules. The Sprint, which focuses on straight-line speed, and the Endurance, which requires maximum efficiency. As with many other sections of this manual, this section cannot stand-alone. For one, the Steering section is “how” one maneuvers around the Endurance course and how it is possible to keep the boat in a straight line for the Sprint. It is also important to review the Technical Reports section when considering different configurations.

### **The Sprint**

This competition is run in heats. Two or three lanes are provided and each competitor must stay in their own lane or they are disqualified. Each run of 200 meters is really for time but the head-to-head aspect does affect who your competition will be and when. Consistency is very important, because having only one fast run will not count for many points.

The first challenge is the Qualifying Sprint. This is 200 meters in length and the time for this run is part of your Qualifying Time. In addition to recording your time, you must demonstrate that the boat can be controlled to run in a straight line.

Because the Sprint is so brief, it is run without the solar panels. Two sets of batteries are allowed so while one is being used in the boat, the other should be on shore, being charged by the solar array.

You may choose to have unique components to optimize performance. These are limited to moving or movable parts such as the rudder, propeller, motor and drive train components. There is a temptation to keep the rudder small, to minimize drag, since it is only needed to steer the boat in a straight line. Just be sure it is not too small.

Using the maximum amount of power available from the batteries is the big challenge. The use of more than one motor is allowed but whatever motor or motors are used, they must remain in place in the boat. This means there may be a need to have an easy way of connecting and disconnection one or more motors to the drive system.

Once the motor configuration is defined, it is likely that a matching prop may not be the same one as the one that will be used in the Endurance configuration.

### **Endurance**

This competition is run in two 90-minute heats, one in the morning and one in the afternoon. Total points are based on the total distance covered in the two, 90-minute events. It is really a time-rate-distance problem. The time is fixed so the rate wants to be as fast as you can go on the stored power in your two batteries and all the solar energy you can use. It is very important to design the system so that all solar energy goes directly to the motor.

Qualifying is done around a closed course. The course requires left and right turns. It is necessary to stay on the course. It begins from a standing start and is timed. This time is a large part of your overall Qualifying Time.

Endurance qualifying is run in Endurance configurations so it includes the solar array. Since speeds will be much less than for the Sprint, and since turning is important, it may be desirable to change rudders, or reach a design compromise for the two events.

It is highly likely that you will be using only one motor but that is your decision. Again, matching the propeller to the motor through a drive train that optimizes RPM is most important.

Unlike the other events, instrumentation is very important. This is discussed elsewhere but the key is having some measure of energy consumption to be able to intelligently set the speed of the boat.

Before finalizing either configuration, there are several factors to consider. Have we balanced our approach between the Sprint and Endurance? The Rules do not require it, but if you want to do well in the Overall standings, it is necessary.

The ease of mounting of the solar panels and their electrical and mechanical attachment is also very important. There is limited time for Solar Cup so it may be necessary to switch configurations several times. Under perfect weather conditions, you may only have to switch twice. But, depending on a variety of factors, it could be three or even four times.

Finally, be sure to consider the tradeoffs between optimization of components and the risks involved in making many changes under time pressures.

# Chapter 5—Electrical System

Before discussing the electrical system of a solar-powered boat, it is important to understand some basic concepts and terms relating to electricity. Current, voltage, resistance, power, and wire sizes will be defined and discussed first.

## Electricity Fundamentals

### Current

Current is a measure of the flow of electrical charge. The units used for current are Amperes, or just Amps (A). The amount of current expected in a circuit determines the size of the wire. More current requires larger wires. Running large amounts of currents through small wires can be done, but this will cause the wires to heat up, resulting in power losses in the system and creating a potential fire hazard. Using a wire that is “too large” does not create problems other than the fact that the wire costs and weighs more.

Current generally falls into one of the two broad categories:

- Direct current (DC) implies that the current is constant, or at least does not have a periodic nature, such as the current provided by a battery or solar panel.
- Alternating current (AC) implies that the current has a sinusoidal nature, such as standard household current.

### Voltage

Voltage is a measure of electrical “potential”. The units for voltage are Volts (V). The voltage, in conjunction with the resistance in a circuit, determines how much current will flow. Higher voltages have the potential to cause higher currents to flow. Unlike current, voltage level does not determine the size of the wire. Voltage level determines the type and thickness of the insulation on the wire. Higher voltages require more insulation for safety reasons.

### Resistance

Resistance is determined by the type and size of the material through which current will flow. The units for resistance are Ohms ( $\Omega$ ). Ohm’s Law defines the relationship between current, voltage, and resistance:

- $R=V/I$  or  $(V=I*R)$

This relationship is a simple linear relationship. For a fixed resistance, as the voltage increases the current increases proportionally. For a fixed voltage, as the resistance decreases the current increases proportionally.

## Power

Power is a rate of consumption of energy. Power in an electrical circuit is determined by the voltage and current levels as follows:

- $P=V * I$  (Power in an electrical circuit)

The units of power are Watts (W). 1 Watt =1 Volt x 1 Amp. Combining the formula for power with Ohm's Law gives other formulas for calculating power when there is a resistance in the circuit:

- $P=I^2 * R$ ,  $P= V^2 / R$  (Power in a resistive circuit)

Energy is determined as follows:

- $E=P * t$  (Energy)

There are numerous units for energy that depend on the time units used. If time is measured in seconds (s), then the units of energy are Watt-seconds (Ws), or Joules (J). If time is measured in hours (h), then the units of energy are Watt-hours (Wh).

## Wire Sizes

Wires, generally made of copper, are conductors of electricity. Silver actually conducts electricity better than copper, but is not often used because of its cost. The cross-sectional area of the wire determines the resistance of the wire per unit length: The larger the wire, the smaller the resistance and therefore the more current that the wire can safely carry without overheating.

Wires come in standard sizes, known as "gages". Standard gages are referred to by their American Wire Gage (AWG) number. The smaller the wire gage number, the larger the wire, e.g. a 4 AWG wire is larger than a 12 AWG wire. The wire gage table is included at the end of this section for reference.

Wire can be solid or stranded. The finer the strands of wire are, the more flexible the wire will be. In DC and low frequency AC applications, the current carrying capability is not affected by the number of strands in a wire, just by the total cross-sectional area of the wire. Finely stranded wire is easier to work with because of its flexible nature, but it is more expensive.

## Electrical Connections

Electrical connections are most often made in "series" or in "parallel", as shown in Fig. 1 and Fig. 2 below. Batteries are typically not connected in parallel, only in series. Loads, or resistances, are typically connected in parallel, but can be connected either way.

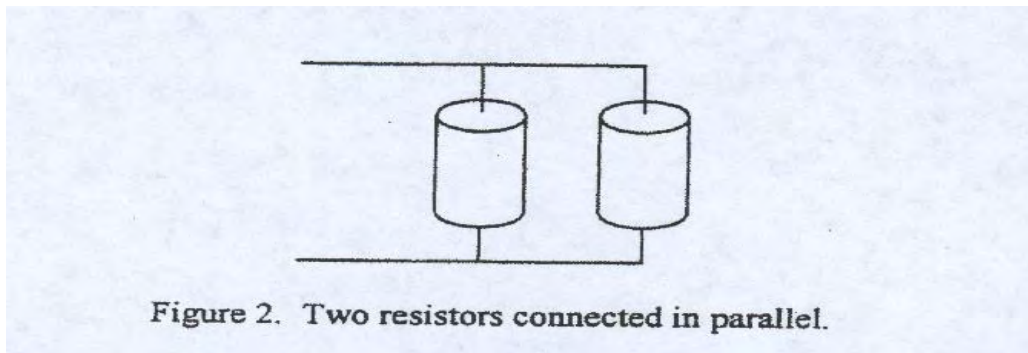
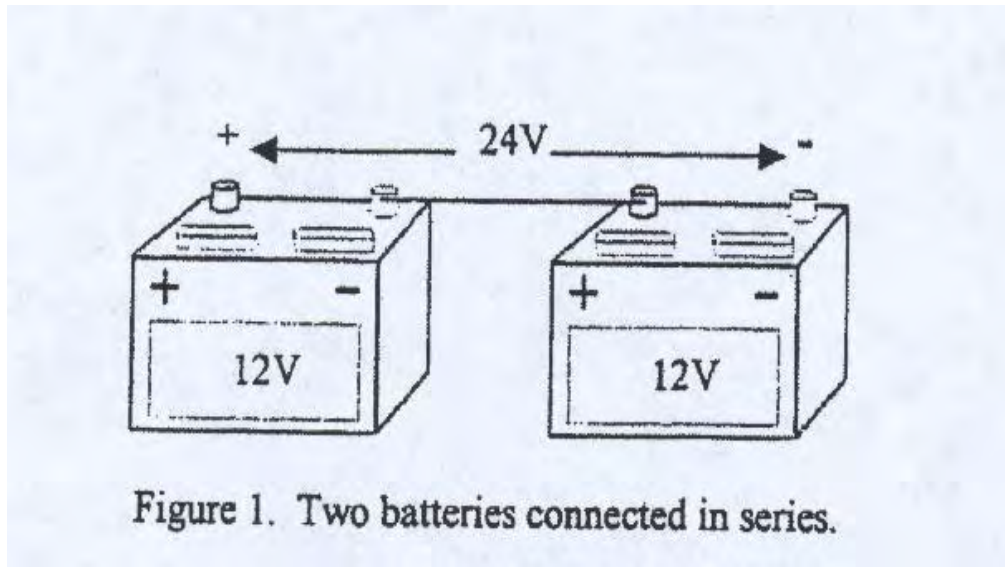

Some important rules to remember about series and parallel circuits are:

- Circuit elements that are in series always have the same current flowing through them
- Circuit elements that are in parallel have the same voltage across them

### Solar Boat Issues

The main components in the electrical system are the solar panels, the batteries, the motor controller, and the motor. There may also be a peak power tracker (see the Solar Panel chapter) and instrumentation circuitry (see the Instrumentation chapter).

A simple wiring diagram, or schematic, is shown in Fig. 3. Note that the solar panel and batteries are connected in parallel.

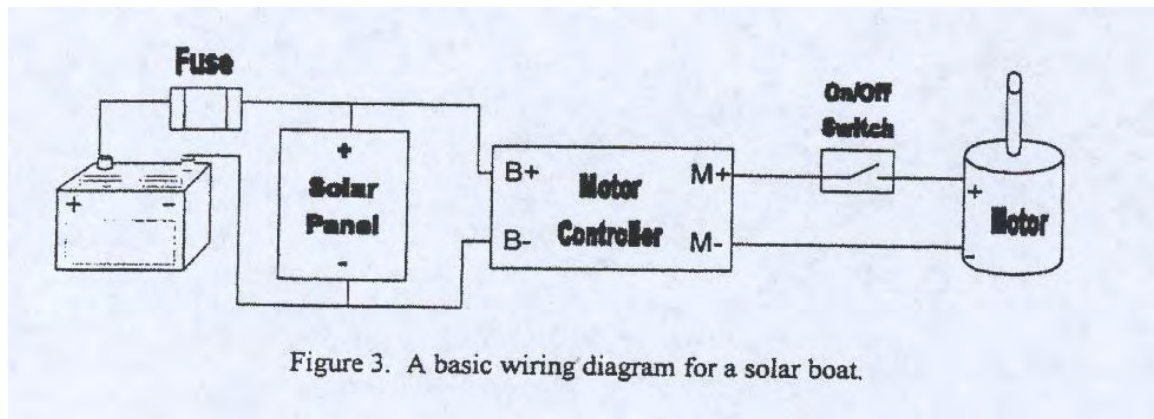

Note that this is a simplified block diagram. Additional components are required to complete the wiring, such as a speed control dial for the motor controller and a “deadman’s switch”.

### Handling High Current

Current levels in the Sprint competition can be quite high, which can cause component failure if the components are not properly sized. The purpose of the 350A fuse is to prevent higher currents in the system, but current levels approaching 350A must be dealt with carefully. **Contactor relays with the appropriate current rating are required for all boats.** The contactor relay must be rated for 24 V and continuous duty rating of at least 200 Amps. Example contactor relays include Alltrax part # SOL-24V-200A, MZJ-200D or Ametek 24144.

The National Electric Code (NEC) specifies that the maximum current for a 0000 wire (see the Wire Table on the following page) is 385A, and the maximum current for a 000 wire is 330A. There are a number of considerations that determine this rating, some of which do not apply to the Sprint competition. For example, the NEC rating is for continuous use, where the Sprint event typically lasts less than a minute. Also, the lengths of wire used in a solar boat are usually much shorter than what would be used in a commercial application. Nevertheless, if your motor is going to draw over 300A, you should probably use wire no smaller than 00. Remember, smaller wire will introduce more loss in your system.

Wire is not the only component affected by the high motor current. Any switches or relays that are used in the circuit must be capable of handling the expected currents. Also, wire terminals (the connectors put on the ends of the wires) and connector blocks must be properly sized and tightly connected. Wire terminals that are crimped onto the wire should be crimped with a high-quality crimper to insure a good connection. All connections should be inspected and cleaned regularly. Loose or corroded connections introduce losses and create a fire hazard.

## Kill Switch

A kill switch, or “dead-man’s switch,” is a switch that will cut power to the motor in the event of an emergency. Typically, one end of a lanyard is connected to the switch, and the other end is connected to the skipper—either to the skipper’s arm or life vest. If the skipper exits the boat, the lanyard will cause the switch to disconnect power to the motor.

The figures on the next page show typical wiring diagrams for two motor controllers. The kill switch could be used in place of the “key switch” on either of the diagrams. Alternatively, if a key switch is used, the kill switch could be placed in series with the key switch. Note that the kill switch is placed in an area of low current, i.e. the current used to control the controller. It is not used in the high current circuitry between the motor controller and the motor. This kill switch should be wired to disconnect power to the motor when the switch is shorted.

If a motor controller is not used, which may be the case in the Sprint event, then the kill switch will need to be placed in the control wiring circuitry of a relay, or contactor, that is used to break full motor current. The contactor relay must be rated for 24 V and continuous duty rating of at least 200 Amps. Example contactor relays include Alltrax part # SOL-24V-200A, MZJ-200D or Ametek 24144. **Under no circumstances should full motor current be run through the kill switch.**

Typical wiring diagram for the Alltrax controller showing the batteries, motor, controller, and various protective devices ([www.alltraxinc.com](http://www.alltraxinc.com)). Note the location of the key switch; this is the same location that a kill switch would be placed.

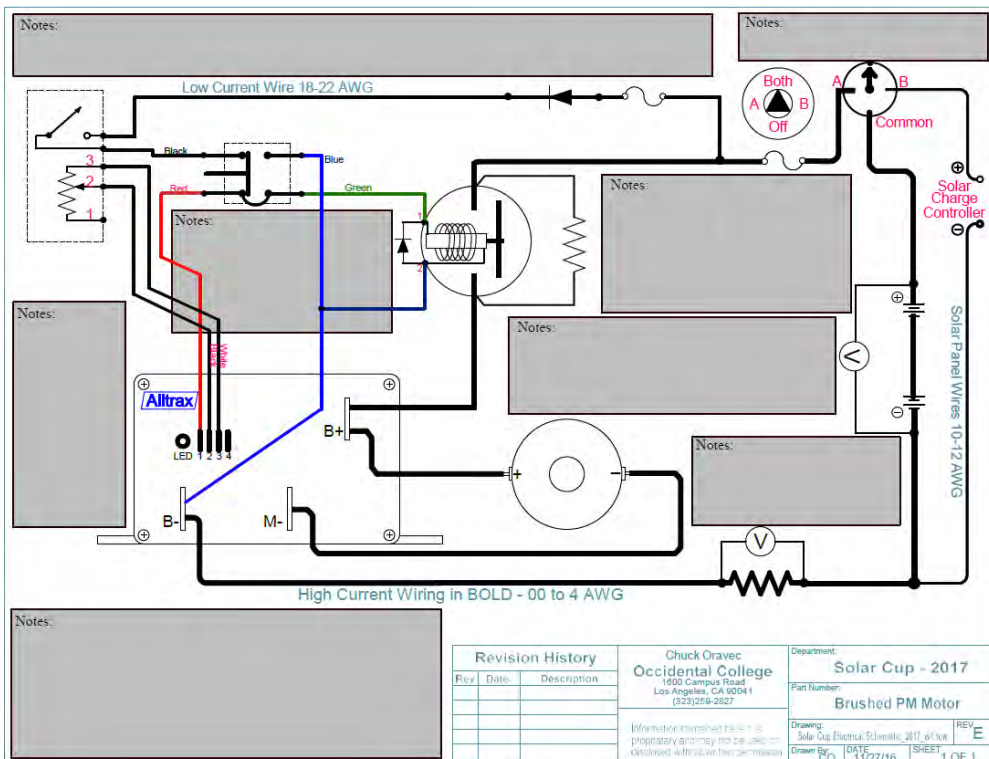

[larger view]

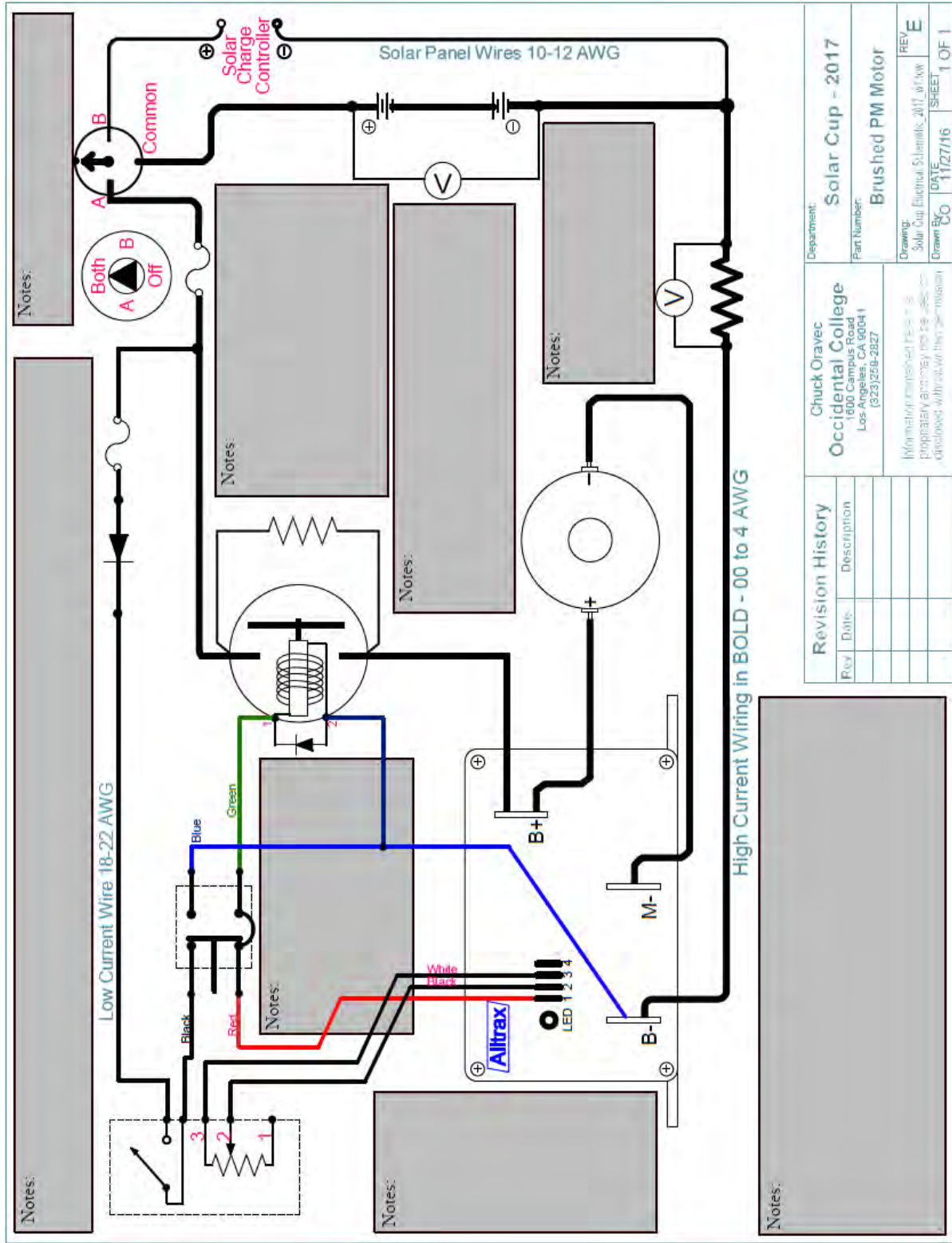

Revision History		Department: Solar Cup - 2017	
Rev	Date	Description	Part Number:
			Brushed PM Motor

Drawing: Solar Cup Electrical Schematics 2017 v1.0  
 Drawn By: [Signature] DATE: 11/27/16 SHEET: 1 OF 1  
 REV: E

Occidental College  
 1600 Campus Road  
 Los Angeles, CA 90041  
 (323) 259-2827

Information furnished herein is for  
 proprietary and may be used without  
 disclosure without the permission

## Chapter 6—Batteries

Lead-acid batteries are chemical-energy storage devices. As with other batteries, the main components are two electrodes and an electrolyte. The electrodes in a lead-acid battery are made of lead and lead-oxide. The electrolyte is typically sulfuric acid.

Several factors determine the characteristics of a lead-acid battery:

- Number of cells
- Type of electrolyte used
- Structure of the anode and cathode plates
- Overall size and weight

A lead-acid battery is typically a series connection of several individual voltaic cells. A single lead-acid cell measures approximately 2.1 volts (V) when fully charged. It is usually referred to as a 2V cell. A “12-volt” battery consists of 6 of these cells internally connected in series. Therefore, a fully charged 12-volt battery will measure approximately 12.6 Volts.

The electrolyte in a lead-acid battery is typically a concentrated sulfuric acid. Often the acid is in a liquid form. More expensive gel-cell batteries are also available. Since the electrolyte in gel-cell batteries is not liquid, the battery may be used in various orientations without the danger of the acid leaking out of the battery. For this safety reason, gel-cells are used in jet skis, wheelchairs, lawn mowers, and other applications where there is a chance of tipping the battery.

The geometry of the battery plates determines some of the current and capacity characteristics of the battery. Thin plates with large surface areas give high currents that may be needed in motor starting applications. Thicker plates are used in deep-cycle batteries.

The capacity of the battery is largely determined by the overall size of the plates—the more lead in the battery, the more capacity the battery will have, all other characteristics being the same.

### Capacity

Battery capacity is typically given in units of ampere-hours or amp-hours (Ah). The capacity is measured as fully charged battery discharges until it reaches some “final” voltage level, such as 10.5 V, though this voltage value may vary among manufacturers.

- A battery that will produce a current of 16 Amps for 2 hours has a capacity (C) of:
  - $C = 16 \text{ A} \times 2 \text{ h} = 32 \text{ Ah}$

Battery capacity varies with the rate of current drawn from the battery. For this reason battery capacity is given as “C/#”, where # is a number of hours. In the example above, the capacity of the battery would be given as  $C/2 = 32 \text{ Ah}$ .

The higher the current draw, the less total capacity the battery will have. In the example above, if the same battery is used to supply 1 A of current, the battery will supply more than 32 hours at that current level. If the battery is used to supply 32 A of current, the battery will last less than 1 hour.

The nonlinear nature of battery capacity is described mathematically by Puckert's Equation:

- $C_2 = C_1 (I_1 / I_2)^{n-1}$

Where

$C_1$  and  $C_2$  are the capacities at current levels  $I_1$  and  $I_2$ , respectively, and  $n$  is a constant specific to the battery, but can be approximated as 1.25 for lead acid.

For example, at a rate of 16A ( $I_1$ ) the battery in the previous example had a capacity of 32 Ah ( $C_1$ ). At a rate of 1 A ( $I_2$ ), the capacity would be:

- $C_2 = 32 (16/1)^{1.25-1} = 32 (2) = 64 \text{ Ah}$

So, lowering the current rate by a factor of 16 doubled the capacity of the battery. Smaller changes in current draw will result in smaller changes in battery capacity.

The capacity of a lead-acid battery varies with the age of the battery and the number of discharge/charge cycles it has experienced. The capacity often increases after several cycles, and then decreases slowly over the life of the battery. This "break-in" period may vary among battery types. Consult the manufacturer for information regarding charging battery capacity over time.

### Battery Data Sheets

Manufacturers' specification sheets for batteries vary considerably. Batteries used in motor starting applications typically list "cranking amps" (CA) or "cold cranking amps" (CCA). These numbers are typically given for temperatures of 32°F and 0° F, respectively. This data provides little information about the capacity of the battery, but may be useful in determining the amount of current that can be drawn quickly from the battery.

Some data sheets give capacity or "reserve capacity" (RC) information. If the time period or current rate is not specified, the capacity is typically given as the number of minutes to discharge at the 25 A rate. Puckert's Equation can be used to approximate the capacity at other current or time rates.

Other information given on a battery specification sheet includes external dimensions, weight, voltage, color, etc. A typical data sheet is included at the end of this section.

## Battery Charging

Batteries must be charged with a source whose voltage is higher than that of the batteries, so that current can flow from the charging source into the batteries. As a battery charges, its voltage will increase. A 12-V battery is generally considered charged when its voltage while charging reaches approximately 15.3 V. Follow the manufacturer's recommendation for maximum charging voltage, as some batteries do not tolerate higher charging voltages.

When a liquid electrolyte 12-V battery reaches approximately 15.3 V the electrolyte will begin to bubble as the water in the electrolyte is broken down into hydrogen and oxygen. This will eventually require water to be added to the cells as the level of the electrolyte decreases. If the battery is "overcharged" for too long, the cells will "boil dry" and the battery will be ruined. Occasional overcharging is necessary to "equalize" the cell, since the cells will not necessarily charge at the same rate each time even though they are connected in series.

Batteries may be charged separately or in series. If two batteries are connected in series, the charging voltage level must be doubled. Batteries generally should not be charged or operated in parallel.

Charging batteries with solar panels can be as simple as connecting the positive to the positive and the negative to the negative, assuming the panel open-circuit voltage is higher than the battery voltage. The battery voltage should be monitored periodically during the charging cycle. When the battery voltage is sufficiently high, the panel can be disconnected, and the battery is fully charged.

## Battery Safety

The sulfuric acid in lead-acid batteries is potentially very dangerous. It is strong enough to cause severe skin burns and can cause blindness if it gets into the eyes. For this reason safety glasses should always be worn when working around batteries. Ordinary baking soda (sodium bicarbonate) can be used to neutralize acid spills and should be kept nearby.

When batteries charge or discharge, heat is produced. If the charge or discharge is done at a high enough rate, the electrolyte can heat to boiling, increasing pressure within the battery, and can cause the battery to crack or explode. Most batteries are vented to prevent pressure buildup, but these vents are often too small to protect against rapid heating. Because of this potential danger, batteries should be operated away from the skipper and should be enclosed in protective battery boxes.

As batteries charge they produce hydrogen gas. If they are charged in an enclosed area, the hydrogen can accumulate, causing a fire or explosion hazard. For this reason batteries should not be charged in an enclosed area, and sparks, flames, and smoking should not be allowed around charging batteries.

Care must be taken when using tools around batteries. A wrench or other metal tool dropped across the terminals of a battery causes a short circuit, which produces a very large amount of current very quickly. This will generally result in sparks flying, the tool becoming very hot, the tool and/or the battery terminals being damaged, and the battery possibly being damaged or destroyed. Tools used around batteries, particularly wrench, should be heavily taped on one end with electrical tape or should be short enough so that they do not reach between the battery terminals.

## Partial List of Battery Manufacturers

The following are companies who make at least one battery model that complies with Solar Cup specifications. The location of each company's headquarters is shown.

Often, it is not possible to buy directly but you may be able to get the name of a local distributor. Generally, batteries are made to industry standards for size. These are known as Groups. The most common applications for Group U-1 are "Lawn & Garden" (typically riding mowers) and for wheelchairs.

When used for a riding mower, they are just used for starting, as in a car. Therefore, these batteries may be quite inexpensive, on the order of \$20, but they will not have optimum capacity. The batteries for wheelchairs and marine applications are designed as "deep cycle". That means they are in relatively continuous uses and must be able to be drained quite low, and still recover rapidly when recharged. This is the type that comes closest to the needs of Solar Cup. As with so many things, you get what you pay for. Remember, you will need a total of 8 batteries.

<b>Manufacturer</b>	<b>Sold as</b>	<b>Model #</b>	<b>Reserve @ Amps</b>
Concorde Battery Corp West Covina, CA	Chairman	AGM-1234T	50 minutes@25
Hawker Energy Products Warrensburg, Missouri	Odyssey	PC925	53 minutes@25
Johnson Controls Milwaukee, WI	Interstate	SP-24, 30, 40* DCS-33	20-45 min@25 unknown
MK Batteries Anaheim, CA	MK	U-1 8AU1 ES33-12	31-34 minutes@25 54 minutes@25 Unknown
Midstate Battery Bloomfield, CT	Sportsman Gel-Tech Power-Tech Lifeline	Jet Ski 8GU1 8AU1 GPL-U1T	19? 44 48 50
Trojan Battery Co Santa Fe Springs, CA	Trojan	U1	50 minutes@25

\*Makes several models.

# DCS-33/DCS-33H



**DCS-33/DCS-33H**  
**VALVE-REGULATED**  
**LEAD-ACID BATTERY**  
**FOR DEEP-CYCLE**  
**MOBILITY APPLICATIONS**  
**12V 29 AH @ 5 HR RATE**  
**12V 33 AH @ 20 HR RATE**

### FEATURES

- Robust plate for extended cycle life.
- Computer-generated grid design optimized for high power density.
- Low calcium grid alloy for reduced gas emissions and ease of recycling.
- Flame-arresting, one-way pressure-relief vent for safety and long life.
- UL-recognized component.
- Multicell design for economy of installation and maintenance.
- Case and cover available in standard polypropylene.
- Thermally welded case-to-cover bond to eliminate leakage.
- Removable carrying handles on DCS-33H.
- Can be used in any orientation. Up-right, side, or end mounting recommended.
- Absorbent Glass Mat (AGM) technology for efficient gas recombination of up to 99% and freedom from electrolyte maintenance.
- Not restricted for air transport – complies with IATA/ICAO Special Provision A67.
- Not restricted for surface transport – classified as non-hazardous material as related to DOT-CFR Title 49 parts 171-189.
- Not restricted for water transport – classified as non-hazardous material per IMDG Amendment 27.
- Longest cycle life available – 900 cycles at 20 amp. hour cycling at 4.6 amps.
- Manufactured by an ISO9001 certified facility.

### 12-Volts – 33 Ampere Hour Capacity @ 20 Hour Rate

Ampere Hour Capacity to 1.75 Volts per Cell @ 77°F (25°C)

Discharge in Hours	1.00	2.00	3.00	4.00	5.00	6.00	7.00	8.00	10.00	12.00	20.00	24.00	72.00	100.00
Amp-Hr Capacity	23.5	25.9	27.2	28.1	29.0	29.7	30.2	30.5	31.0	31.5	33.0	33.1	33.8	34.4

**Interstate Battery**  
**System of America, Inc.**  
 12770 Merit Drive  
 Suite 400  
 Dallas, TX 75251  
 Customer Service: 1-888-772-3600



Printed in the U.S.A. 701 AB  
 © 2001 Interstate Battery System of America, Inc.

[interstatebatteries.com](http://interstatebatteries.com)

# DCS-33/DCS-33H

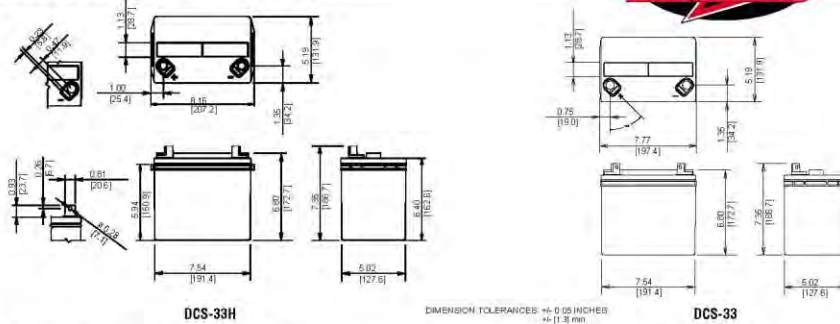

DCS-33H

DIMENSION TOLERANCES: ±0.05 INCHES  
±1.5 mm

DCS-33

\*All dimensions in inches and (millimeters). All dimensions are for reference only. Contact an Interstate representative for complete dimensional information.

## DCS-33 – Specifications

BCI Group Size	Cells Per Unit	Full Charge OCV	Weight	Electrolyte	Max. Discharge Current	Short Circuit Current	Ohms Imped. 60 Hz (Ω)
U1	6	12.84	27 lbs. 12.3 kg	Absorbed H <sub>2</sub> SO <sub>4</sub> SG = 1.300	600 Amps	2150 Amps @ 0.1 sec.	0.007 Ohms

<b>Capacity</b>	29.0 Ah @ 5 hr. rate to 1.75 volts per cell @ 77°F (25°C) 33.0 Ah @ 20 hr. rate to 1.75 volts per cell @ 77°F (25°C) 29.6 Ah @ 10 hr rate to 1.80 volts per cell @ 20°C (68°F)
<b>Operating Temperature Range</b>	<b>Discharge:</b> -40°F (-40°C) to +160°F (71°C), <b>Charge:</b> -10°F(-23°C) to +140°F(60°C) (with temperature compensation)
<b>Recommended Operating Temperature Range</b>	+74°F (23°C) to +80°F (27°C)
<b>Float Charging Voltage</b>	13.5 to 13.8 VDC/unit Average at 77°F (25°C).
<b>Recommended Maximum Charging Current Limit</b>	C/5 amperes (6.6 amperes @ 100% depth of discharge) @ 20 hour rate
<b>Equalization and Cycle Service Charging Voltage</b>	14.4 to 14.8 VDC/unit Average at 77°F (25°C).
<b>Maximum AC Ripple (Charger)</b>	0.5% RMS or 1.5% P-P of float charge voltage recommended for best results. Maximum AC ripple float charge voltage allowed = (4% P-P) Maximum AC ripple current allowed = 1.65 amperes RMS (C/20)
<b>Self Discharge</b>	Interstate's batteries may be stored for up to 6 months at 77°F (25°C) and then a freshening charge is required. For higher temperatures the time interval will be shorter.
<b>Terminal</b>	"L" terminal with 0.28" clearance hole to accept 0.25" (6mm) bolt.
<b>Terminal Hardware Initial Torque</b>	40 in.-lbs. (4.5 N-m).
<b>Terminal Hardware Annual Retorque</b>	32 in.-lbs. (3.48 N-m).

## Discharge Ratings (in amps) at Constant Discharge Time (in hours)

End Point Volts/Cell	.083	.25	.50	.75	1	2	3	5	8	10	12	20	24	72	100
1.90	87.0	46.0	30.0	24.0	18.1	11.0	8.03	5.20	3.39	2.73	2.38	1.42	1.19	0.42	0.30
1.85	101	55.2	34.0	27.2	20.5	11.8	8.40	5.48	3.58	2.90	2.51	1.54	1.29	0.45	0.33
1.80	113	61.2	37.2	29.7	22.3	12.4	8.80	5.64	3.71	3.02	2.59	1.61	1.35	0.46	0.34
1.75	121	67.2	40.0	31.7	23.5	13.0	9.07	5.80	3.81	3.10	2.62	1.65	1.38	0.47	0.34

Notes: Batteries to be mounted with 0.5 in. (1.25 cm) spacing minimum and free air ventilation. Specifications subject to change without notification.



## Chapter 7—Solar Array

A photovoltaic (PV) cell converts light energy directly into electricity. A solar panel is made up of many PV cells connected in series. The characteristics of a solar panel are best described by a graph of current versus voltage, as shown in Fig. 1 below.

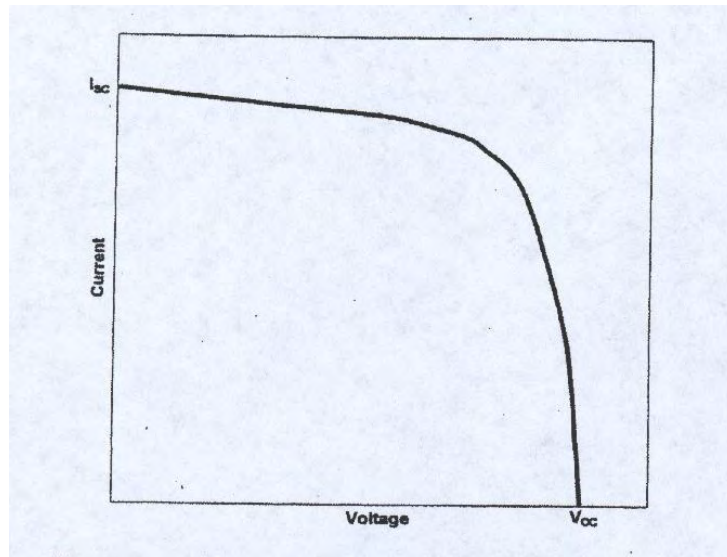

Figure 1. Solar panel current versus voltage characteristics

The maximum, or short-circuit, current ( $I_{SC}$ ) that shows the panel will produce occurs when the wires from the panel are shorted together. This shows that the current is limited, unlike the current from a battery or other voltage source. This figure also shows that over a wide range of voltage, the current is nearly constant.

While the current and voltage characteristics of a solar panel are important to understand, the most important quantity is the power produced by the panel. The power that the panel produces varies with the voltage and current levels. Figure 2 shows both the current versus voltage and power versus voltage characteristics of a typical panel.

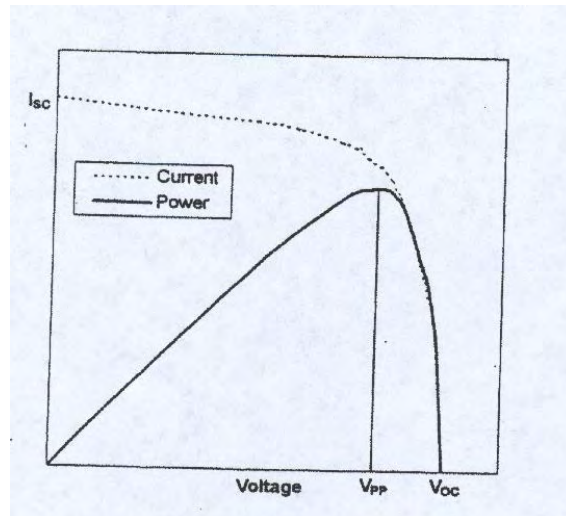

Figure 2. Solar panel I-V and P-V characteristics

In Figure 2 the power ( $P=V \cdot I$ ) is shown as a function of voltage. This power curve shows that there is a voltage ( $V_{PP}$ ) at which the power from the panel is maximized. Operating the panel at this voltage will make the best usage of the power available from the panel.

It is important to note that the panel does not necessarily tend to operate at this “peak power point” (PPP). The panel is perfectly satisfied operating anywhere along its characteristic curve. Other devices in the circuit, such as batteries and motors, determine where it operates on its characteristic curve.

A panel that is rated at 40 Watts under “one sun” conditions will produce 40 W of power only at the PPP. At a voltage other than  $V_{PP}$ , the panel will produce less power than it does at the PPP, often much less. Ideally, the panel should always be operated at its PPP. In practice this is not a simple problem.

If the batteries and solar panels are connected together directly in parallel, then the battery voltage will essentially control or determine the solar panel voltage. If this voltage is not  $V_{PP}$ , then the panel will not be fully utilized, i.e. it will not be putting out its maximum power. Also, the battery voltage will vary with the load on the battery, i.e. the amount of current being drawn from the battery. The battery voltage also decreases as the battery discharges, so even if the voltage were  $V_{PP}$  initially, it would decrease below  $V_{PP}$  over time as the battery discharges. Furthermore, the solar panel characteristics change as sunlight conditions change, which also moves the peak power point.

So, how can solar panels be operated at their peak power points at all times? A device called a “peak power tracker” (PPT) is designed to do this automatically. (Don’t confuse a PPT with a device that points the panels at the sun. It does not have any moving parts.) The PPT is an electronic device that is placed between the solar panels and the batteries. It is essentially a smart DC-DC converter that tracks the peak power on the power graph and keeps the panel operating at  $V_{PP}$ . The solar panel voltage is maintained at  $V_{PP}$ , and

the PPT converts the panel voltage to the battery voltage. PPT efficiency is typically 95% or better.

For example, a certain panel has  $ISC = 4$  A,  $VOC = 17.5$  V, and produces its peak power at a voltage of 14.5 V and a current of 3.3 A. The peak power that the panel can produce is

- $P = V * I = 14.5 * 3.3 = 47.85$  W (peak panel power output)

If this panel is operated at 12 V, it gives a current of 3.63 A, which gives a panel output power of

- $P = 12 * 3.63 = 43.56$  W (panel output at 12V)

So, if this panel were connected directly to a battery at a voltage of 12 V, it would produce only 43.56 W of power.

If a 95% efficient peak power tracker were placed between the panel and battery, the power to the battery would be

- $P = 47.85 * .95 = 45.46$  W, (effective panel output with a PPT)

an increase of 1.9W. The current from the PPT would be

- $I = P / V = 45.46 / 12 = 3.79$  A (PPT current output at 12 V)

This may not seem like a large power gain, but the effect would be much greater as the battery voltage decreased. If the battery voltage under the load of a motor decreased to 10 V, the power from the tracker would still be 45.46 W. The current from the PPT would be

- $I = P / V = 45.46 / 10 = 4.55$  A (PPT current output at 10 V)

Note that this current is greater than the short circuit current for the panel. Without a PPT the power from the panel would be

- $P = 10 * 3.75 = 37.5$  W, (panel output at 10 V w/o a PPT)

which is 8 W less than with a PPT.

Note: the numbers used in this example are taken from the numbers used to generate figures 1 and 2.

It is beyond the scope of this handbook to discuss how a PPT works. It is a complicated electronic circuit with feedback and is not easily designed or constructed. However, PPTs are available commercially. The main specifications for the PPT are voltage and current levels expected.

## **SOLAR PANEL CONNECTIONS**

Solar panels can be connected together in series or in parallel. For definitions of these terms, refer to the Electrical System chapter. Connection two identical panels together in series will double the voltage from the panels, and both panels will have the same current flowing through them. Connecting two identical panels together in parallel will double the current available from the panels, and both panels will have the same voltage across them.

Consideration must be given to the connections between the solar panels and the boat's electrical system. Keep in mind that throughout the course of building, testing, and competing with the boat, the panels will be put on and taken off of the boat many times. The connections to the boat's electrical system should be tight, reliable connections, but they should also be easily removable. The polarity of the wires should also be considered – a good design would make it impossible to connect the wires incorrectly.

You may also want to install a panel disconnect switch that can be easily operated from the cockpit. This will be convenient when the panels are charging batteries during the competition and the batteries have reached a state of full charge, such as may be the case while waiting at the start line for the Endurance event to begin.

Solar panels will be inspected for compliance with the Rules regarding maximum allowable power (320 W) by reviewing the manufacturer's specifications for the panels. If your team builds its own panels from individual cells, information about the cells must be provided for the electrical inspector. Solar panel open circuit voltage will also be obtained from manufacturer's data and may be measured at inspection time.

Consideration must be given to acquiring solar panels of appropriate voltage and power levels. A typical panel used with a 12 V battery system has an open-circuit voltage of around 17V. If your team were using a 24 V system, then you would want two solar panels connected in series to give an open-circuit voltage of around 34 V. Perhaps several pairs of panels would then be connected in parallel. This implies that you would want an even number of solar panels whose total power adds up to 320 W or less.

In addition to the voltage and power levels, consideration must be given to the size and weight of the panels. The panels must be mounted on the boat in such a way that they do not extend beyond the gunwales of the boat more than the distance permitted by the Rules. The panels should be durable and easy to install and uninstall, since they will be attached and removed many times.

## **EXAMPLES OF COMMERCIALY AVAILABLE SOLAR PANELS**

The following pages are just examples of the kinds of information that is available about commercially available panels. Let's start with the summary that follows.

This page was done in about 2001 as a compilation of what one individual was able to put together. It serves many functions. First, it is an impressive list of the names of many manufacturers. Secondly, it is an easy way of finding potentially useful panels as it includes sizes and weights. Some panels are much too heavy to consider while others are too large to fit within the overhang limits in the rules.

Model numbers may change, but when they do, most manufacturers simply replace the model 115 with a model 215 or some similar numbering system.

The second sheet focuses in on several models that will generally satisfy the rules of Solar Cup. With these in mind, you can begin to contact sources. Many companies will have local sales organization in the area. Although the tendency is to go directly to the manufacturer, sometimes the local organization will have demo panels that they can sell at much reduced prices. There are many solar panels floating around various Universities and Colleges. If you can find a group that has done work with panels, you may get hardware and help.

Finally there are several sets of data sheets. These give you some idea of the visual appearance of the panel and may provide additional information on mounting. Ideally, you would like to get the greatest output for the least weight.

**REMEMBER, THIS INFORMATION IS PROVIDED TO GET YOU STARTED.  
PRODUCT, INVENTORY AND COSTS WILL ALWAYS BE CHANGING SO IT IS UP TO  
YOU TO SEEK OUT WHAT YOU NEED TO FIT YOUR REQUIREMENTS.**

# COMMERCIALLY AVAILABLE SOLAR PANELS

Brand	Model No.	Watts	Watts per sq. Foot	Watts Per lb.	Icc (amp ps)	Vac (volts)	Length (inches)	Width (inches)	Panel Weight (lbs)	# of panels for 480W	Array Weight (lbs)	Panel Area (sq ft)	Total Area (sq ft)	Area/ Amp (sqft/ amp)	Array Current	Rated Volts	Rated Amps	Nominal Volts	COST	
UniSolar	U9-21	21	5.483	7.00	1.27	21	36.55	15.08	3	22.9	68.3	3.83	87.5	3.01	29					
UniSolar	U6-11	11	6.446	6.88	0.62	18.5	19.33	15.06	1.6	43.6	71.1	2.02	88.3	3.26	27.1					
UniSolar	U8F-32	32	4.9	6.81	1.94	16.9	56.27	16.7	4.7	15		6.53	97.9	3.36	29.1					
BP	BP590F	90	13.14	5.45	4.86	18.5	47	21	16.5	5.3	88	6.85	36.6	1.41	25.9					
BP	580	90	13.25	5.46	5.20	22.30	46.80	20.90	16.50	5.33	88.00	6.79	36.23	1.31	27.73	18.5	4.86	12.0	\$523.00	
BP	505F	85	12.53	5.14	5.00	22.30	46.80	20.87	16.53	5.65	93.35	6.78	38.31	1.36	28.24	18.0	4.72	12.0		
Kyocera	LA441063	63	11.03	4.85	3.03	20.7	47	17.5	13	7.6	99	6.71	43.5	1.89	23.1					
BP	580F	80	11.79	4.84	4.70	22.03	46.80	20.87	18.53	6.00	99.18	6.78	40.70	1.44	28.20	18	4.44	12.0		
Solar	9-1100	110	12.24	4.70	6.89	21.30	50.75	25.50	23.40	4.36	102.11	8.99	39.22	1.30	30.07	17.10	6.43	12.0		
BP	6130L	133	11.37	4.64	4.80	36.30	53.14	31.69	28.66	3.61	103.43	11.89	42.21	2.44	17.32	29.8	4.50			
Solaras	M6X-L-30	30	9.119	4.62	1.75	17.1	24.3	19.5	8.5	16	105	3.29	52.7	1.86	28					
Siemens	SF150	150	10.57	4.60	4.80	43.40	63.76	32.05	32.60	3.20	104.32	14.19	45.41	2.96	15.36	34.0	4.40			
Siemens	8N55	55	11.96	4.58	3.16	17.4	50.9	13	12	8.7	104.7	4.6	40.1	1.46	27.5					
Kyocera	KC170-1	120	11.99	4.58	7.1	16.9	56.1	25.7	26.2	4	104.8	10.01	40.11.41	28.4						
Kyocera	KC120	120	11.97	4.58	7.45	21.50	37.90	38.10	26.20	4.00	104.80	10.03	40.11	1.35	29.80	16.90	7.10	12.0		
BP	BP250F	50	11.14	4.55	2.34	17.1	38	17	11	9.6	105.9	4.49	43.1	1.92	22.5					
BP	275	75	11.04	4.55	4.45	21.40	46.80	20.90	16.50	6.40	105.60	6.79	43.47	1.53	28.48	17.0	4.45	12.0	\$399.00	
UniSolar	U8-5	5	4.63	4.55	0.3	16.5	19.33	8.07	1.1	96	108.5	1.08	104	3.61	28.8					
Siemens	SM46	46	11.96	4.61	3.15	14.6	42.7	13	10.2	10.4	106.4	3.85	40.2	1.22	32.9					
Siemens	SF75	75	10.98	4.49	4.4	17	47.3	10.8	16.7	6.4	106.9	6.83	43.7	1.56	28.2					
Solaras	VLX-53	53	10.5	4.42	3.08	17.2	36.9	19.7	12	9.1	106.7	5.05	45.7	1.64	27.9					
Siemens	SM110	110	11.75	4.36	6.3	17.5	51.8	25.98	25.1	4.4	109.5	9.35	40.8	1.48	27.5					
Siemens	SM50-H	50	11.55	4.35	3.15	15.9	48	13	11.5	9.6	110.4	4.33	41.6	1.38	30.2					
Solec	SO-090	90	10.84	4.31	5.63	21.30	52.00	23.00	20.90	5.33	111.47	8.31	44.30	1.48	30.03	17.10	5.26	12.0		
Solec	S-1000	100	11.13	4.27	6.26	21.30	50.75	25.50	23.40	4.80	112.32	8.98	43.14	1.44	30.05	17.10	5.85	12.0		
BP	BP275F	75	10.96	4.26	4.35	17.1	47	21	17.6	6.4	112.9	6.85	43.9	1.58	27.8					
Solaras	SX-120	120	10.44	4.24	3.87	42.10	57.51	28.78	28.30	4.00	113.20	11.49	45.98	2.97	15.48	33.7	3.56			
Solaras	MSX-170	120	10.16	4.20	3.87	42.10	43.63	39.00	28.60	4.00	114.40	11.82	47.27	3.05	15.48	33.70	3.56			
Siemens	SP70	70	10.25	4.19	4.25	16.5	47.3	20.8	16.7	6.9	114.5	6.83	46.9	1.61	29.1					
Siemens	SM50	50	10.87	4.17	3.05	16.6	50.9	13	12	9.6	115.2	4.6	44.1	1.51	29.3					
Siemens	8R50-Z	50	9.452	4.17	2.95	17	32.4	23.5	12	9.6	115.2	5.29	50.8	1.79	26.3					
Siemens	SR100	100	10.43	4.17	6.30	22.00	59.00	23.40	24.00	4.80	115.20	9.59	46.02	1.52	30.24	17.7				
Solaras	VLX-32	32	9.726	4.16	1.86	17.2	24.3	19.5	7.7	15	115.5	3.29	49.4	1.77	27.9					
Kyocera	LA7210102	102	11.04	4.13	3.02	33.8	38.9	34.2		24.7	4.7	116.2	9.24	43.5	3.06	14.2				
Solaras	MSX-84	64	10.63	4.03	3.66	17.5	43.8	19.8	15.9	7.5	119.3	6.02	45.2	1.65	27.5					
Siemens	SM100	100	10.7	3.98	5.9	17	51.8	25.98	25.1	4.8	120.5	9.35	44.9	1.58	28.3					
BP	270UL	70	10.32	3.97	4.48	21.40	46.80	20.87	17.64	6.86	120.96	6.78	46.51	1.51	30.72	17.0	4.16	12.0		
Kyocera	LA361051	51	10.81	3.92	3.02	16.9	38.8	17.5	13	9.4	122.4	4.72	44.4	1.56	28.4					
Solec	S-070	70	10.16	3.89	4.38	21.30	47.25	18.00	6.86	123.43	6.89	47.25	1.57	30.03	17.10	4.09	12.0			
Solaras	6X-110	110	9.57	3.89	3.69	41.20	57.51	28.78	28.30	4.36	123.49	11.49	50.16	3.11	16.10	32.9	3.34			
Kyocera	LA321K45	45	10.71	3.85	3.02	15	34.6	17.5	11.7	10.7	124.6	4.2	44.9	1.39	32.2					
Siemens	SR50	50	9.98	3.85	2.95	17	30.8	23.4	13	9.6	124.8	6.01	48.1	1.7	28.3					
Solaras	M6-110	110	9.31	3.85	3.69	41.20	49.63	39.00	28.60	4.36	124.80	11.82	51.96	3.20	16.10	32.9	3.34			
Solaras	VLX-80	80	10.11	3.83	4.71	17	43.8	26	20.9	6	125.4	7.91	47.5	1.68	28.3					
Solec	SQ-080	80	9.632	3.83	5.01	21.30	52.00	23.00	20.90	6.00	125.40	8.31	49.83	1.66	30.06	17.10	4.68	12.0		
Siemens	SP36	36	10	3.79	2.1	17	24.9	20.8	9.5	13.3	126.7	3.6	48	1.71	28					
BP	BP725	25	9.294	3.79	1.47	17	21.5	18	6.6	19.2	126.7	2.69	51.6	1.83	28.2					
Kyocera	KO80	80	11.68	3.77	4.73	16.9	38.4	25.7	21.2	6	127.2	6.85	41.1	1.45	28.4					
Solaras	MSX-60	60	3.77	3.5	17.1	43.8	19.8	15.9	8	127.2	6.02	48.2	1.72	28						
Siemens	SR90	90	9.385	3.75	5.4	17	58	23.4	24	5.3	128	9.59	51.11.78	28.8						
ASE	ASE-50-AL	50	10.64	3.70	2.9	17	38	17.8	13.5	9.6	129.6	4.7	45.1	1.62	27.8					
Solaras	M6X-77	77	9.735	3.68	4.56	16.9	43.8	26	20.9	6.2	130.3	7.91	49.3	1.73	28.4					
Solaras	MSX-50	50	9.804	3.60	2.92	17.1	37.1	19.8	13.9	9.6	133.4	5.1	49	1.75	28					
Siemens	SM20	20	10	3.57	1.38	14.5	22.3	12.9	5.6	24	134.4	2	48	1.45	33.1					
Solaras	SMX-30	30	9.375	3.53	1.75	17.1	23.3	19.8	8.5	16	136	3.2	51.3	1.83	28					
Kyocera	KC60	60	11.36	3.49	3.55	16.9	29.6	25.7	17.2	8	137.6	5.28	42.3	1.49	28.4					
Kyocera	LA721X34	34	10.43	3.40	2.26	15	26.8	17.5	10	14.1	141.2	3.26	46	1.44	31.9					
Solaras	MSX-40	40	9.662	3.39	2.24	17.1	30.1	19.8	11.8	12	141.6	4.14	49.7	1.85	26.9					
Kyocera	LD361C24	24	9.376	3.38	1.44	16.7	21.1	17.5	7.1	20	142	2.56	51.3	1.78	28.8					
Solaras	MSX-53	53	8.834	3.33	3.2	16.7	43.8	19.8	15.9	9.1	144	6.02	54.5	1.88	29					
UniSolar	US-64	64	6.202	3.17	3.88	16.5	53.78	27.84	20.2	7.5	151.5	10.32	77.4	2.66	29.1					
UniSolar	US64	64	5.87	3.17	4.80	27.10	53.78	29.18	20.20	7.50	151.50	10.90	81.73	2.27	36.00	16.50	3.88	12.0		
Siemens	SP18	18	9.626	3.05	1.1	17	24.9	10.8	5.9	26.7	157.3	1.87	49.8	1.7	29.3					
UniSolar	US-42	42	5.658	3.04	2.54	23.8	36.55	29.18	13.8	11.4	157.7	7.41	84.7	2.92	29					
Kyocera	KC40	40	10.84	3.03	2.34	16.9	20.7	25.7	13.2	12	158.4	3.69	44.3	1.58	28.1					
UniSolar	US-32	32	6.337	3.02	1.94	23.8	53.78	13.52	10.6	15	159	5.05	75.7	2.6	29.1					
ASE	300-DGF/17	300	11.48	2.80	19.10	20.00	74.50	50.50	107.00	1.60	171.20	26.13	41.80	1.37	30.56					
Siemens	SM6	6	9.677	2.73	0.39	15	13	6.9	2.2	80	175	0.62	49.8	1.6	31.2					
Siemens	SM10	10	7.813	2.70	0.61	16.3	14.2	13	3.7	48	177.6	1.28	61.5	2.1	29.3					
Kyocera	LE381C11	11	8.709	2.50	0.66	18.5	20.1	9.6	4.4	43.6	192	1.34	58.5	2.06	28.4					
Solaras	MST-56	56	6.33	1.70	0.67	102.00	48.45	26.30	33.00	8.57	282.86	8.85	75.85	10.16	7.47	73.00	0.75			
Siemens	SR75	75			4.40	17.00				6.40					28.16				\$356.00	

### Solar Panel Specs

Brand	Model No	Watts	Watts Per sq. Foot	Watts Per lb	Isc (Amps)	Voc (Volts)	Length (In)	Width (In)	Panel Weight (lbs)	# of Panels For 320W	Total Power of Array	Array Weight (lbs)	Panel Area (sqft)	Total Area (sqft)
BP Solar	585F	85	12.53	5.14	5.00	22.10	46.80	20.87	16.53	3	255	49.59	6.78	20.35
BP Solar	SX 80U	80	10.18	3.83	5.17	21.00	47.31	19.75	20.90	4	320	83.60	7.86	31.44
Astro Power	AP-6105	65	9.58	3.59	4.60	20.50	47.20	20.70	18.10	4	260	72.40	6.79	27.14
Astro Power	AP-7105	75	11.05	4.14	4.80	21.00	47.20	20.70	18.10	4	300	72.40	6.79	27.14
Photowatt	PW 750	80	10.80	4.65	5.00	21.90	48.70	21.90	17.20	4	320	68.80	7.41	29.63
Kyocera	KC60	60	11.38	3.49	3.73	21.50	29.60	25.70	17.20	5	300	86.00	5.28	26.41
Kyocera	KC80	80	11.67	3.77	4.97	21.50	38.40	25.70	21.20	4	320	84.80	6.85	27.41
Siemens	SM50	50	10.88	4.17	3.40	21.40	50.90	13.00	12.00	6	300	72.00	4.60	27.57
Siemens	SP75	75	10.98	4.49	4.80	21.70	47.30	20.80	16.70	4	300	66.80	6.83	27.33
Siemens	SR100	100	10.43	4.17	6.30	22.00	59.00	23.40	24.00	3	300	72.00	9.59	28.76

The BP 585 photovoltaic module uses the world's leading commercial laser cell processing technology to produce photovoltaic modules with exceptional efficiency. Its premium laser-grooved buried-grid monocrystalline cells provide a premium power performance of 85 watts nominal maximum power and 12 volts of nominal output for DC loads, or with an inverter, AC loads. The BP 585's high efficiency is particularly suited for applications which need maximum energy generation from a limited array area. Applications include utility grid-connected residential and commercial roof systems, building facades, and traditional industrial and remote applications. Modules use our Universal frame, the strongest in the industry.

Available versions include:

BP 585S – Framed module with output cables and polarized connectors

BP 585L – Unframed laminate version of the BP 585S

BP 585U – Framed module with a high-volume Type A junction box

BP 585H – Framed module with our Type B junction box

### Proven Materials and Construction

BP Solar's quarter-century of field experience shows in every aspect of these modules' construction and materials:

- Laser patterning and processing minimizes cell front shading, maximizes efficiency;
- Cells are laminated between sheets of ethylene vinyl acetate (EVA) and high-transmissivity low-iron 3mm tempered glass;
- Frame strength exceeds requirements of certifying agencies.



### DC Connectors

### Output Options

The BP 585 is offered with three output options: Connector-equipped cables and two types of junction box.

**BP 585S and BP 585L** output is via heavy-duty AWG #12 (3.3mm<sup>2</sup>) output cables with polarized weatherproof DC-rated connectors which provide reliable low-resistance connections, eliminate wiring errors, and speed installation. Asymmetrical cables enable side-by-side or end-to-end module placement in arrays.

**BP 585U** output is via our Type A junction box. This junction box is



### Clear Anodized Universal Frame

is raintight (IP54 rated) and accepts PG13.5 or 1/2" nominal conduit or cable fittings. Its volume (411cc, 25 cubic inches) and 6-terminal connection block enable series or parallel array connections to be made right in the junction box. Options include:

- oversize terminal block which accepts conductors up to 25mm<sup>2</sup> (AWG #4); standard terminals accept up to 6mm<sup>2</sup> (AWG #10);
- Solarstate™ charge regulator.

**BP 585H** output is via our Type B junction box, which is raintight (IP65 rated), features a convenient flip screw-tight lid, and offers the same wiring capabilities as the Type A junction box. It is equipped with a versatile 5-terminal Euro-style connection block. Two cable fittings that accept cable with a diameter between 6-12mm are included with each BP 585H module.

### Limited Warranties

- Power output for 25 years;
- Freedom from defects in materials and workmanship for 5 years.

See our website or your local representative for full terms of these warranties.



BP 585



## Quality and Safety

These modules are manufactured in our ISO 9001-certified factories to demanding specifications. The BP 585S, 585U, and 585H:

- are certified by TÜV Rheinland as Class II equipment for use in systems up to 1000 VDC;
- are listed by Underwriter's Laboratories for electrical and fire safety (Class C fire rating);
- conform to European Community Directives 89/33/EEC, 73/23/EEC, and 93/68/EEC;
- comply with the requirements of IEC 61215, including:
  - repetitive cycling between -40°C and 85°C at 85% relative humidity;

- simulated impact of 25mm (one-inch) hail at terminal velocity;
- 2200 VDC frame/cell string isolation test;
- static loading, front and back, of 2400 pascals (50 psf); front loading (e.g. snow) of 5400 pascals (113 psf).

The BP 585L is recognized by Underwriter's Laboratories for electrical and fire safety. The BP 585U is approved by Factory Mutual Research for application in NEC Class 1, Division 2, Groups C & D hazardous locations.

## Electrical Characteristics<sup>1</sup>

	BP 585	BP 580 <sup>4</sup>
Maximum power ( $P_{max}$ ) <sup>2</sup>	85W	80W
Voltage at $P_{max}$ ( $V_{mp}$ )	18.0V	18.0V
Current at $P_{max}$ ( $I_{mp}$ )	4.72A	4.44A
Warranted minimum $P_{max}$	80.8W	76W
Short-circuit current ( $I_{sc}$ )	5.0A	4.7A
Open-circuit voltage ( $V_{oc}$ )	22.1V	22.0V
Temperature coefficient of $I_{sc}$	(0.065±0.015)%/°C	
Temperature coefficient of voltage	-(80±10)mV/°C	
Temperature coefficient of power	-(0.5±0.05)%/°C	
NOCT <sup>3</sup>	47±2°C	
Maximum system voltage	600V (U.S. NEC rating) 1000V (TÜV Rheinland rating)	
Maximum series fuse rating	20A (U, H versions) 15A (S, L versions)	

## Notes

1. These data represent the performance of typical BP 580 and BP 585 modules as measured at their output terminals. The data are based on measurements made in accordance with ASTM E1036 corrected to SRC (Standard Reporting Conditions, also known as STC or Standard Test Conditions), which are:
  - illumination of 1 kW/m<sup>2</sup> (1 sun) at spectral distribution of AM 1.5 (ASTM E892 global spectral irradiance);
  - cell temperature of 25°C.
2. During the stabilization process which occurs during the first few months of deployment, module power may decrease approximately 3% from typical  $P_{max}$ .
3. The cells in an illuminated module operate hotter than the ambient temperature. NOCT (Nominal Operating Cell Temperature) is an indicator of this temperature differential, and is the cell temperature under Standard Operating Conditions: ambient temperature of 20°C, solar irradiation of 0.8 kW/m<sup>2</sup>, and wind speed of 1m/s.
4. The power of solar cells varies in the normal course of production; the BP 580 is assembled using cells of slightly lower power than the BP 585.

## BP 585 I-V Curves

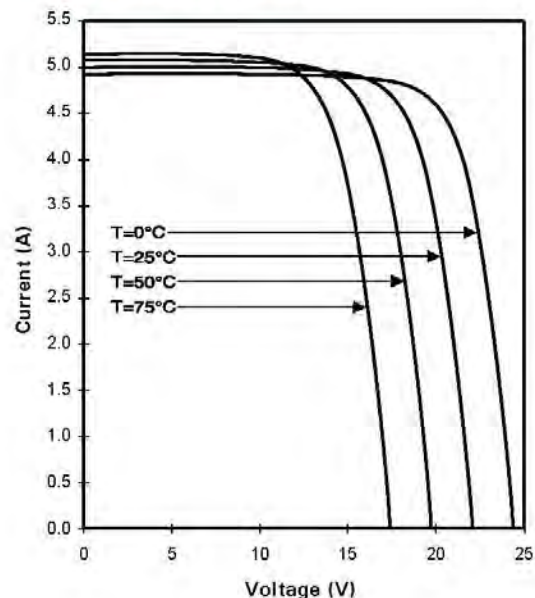

## Mechanical Characteristics

### Weight

BP 585U, 585S, 585H  
BP 585L

7.7 kg (17 pounds)  
6.1 kg (13.4 pounds)

### Dimensions

BP 585U, 585S, 585H: See drawing.  
BP 585L: 1197 [47.1] x 530 [20.9] x 18 [0.7]  
Unbracketed dimensions are in millimeters.  
Bracketed dimensions are in inches.  
Overall tolerances  $\pm 3\text{mm}$  (1/8")

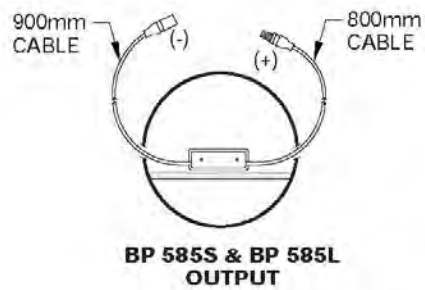

**BP 585**

# AP-6105/AP-7105 PHOTOVOLTAIC MODULES

AstroPower's AP-6105/AP-7105 modules are based on high-efficiency five-inch single crystal solar cells. Crystalline solar cell technology is the industry standard, in use for over two decades in hundreds of thousands of application sites throughout the world. The five-inch AstroPower solar cells build on this extensive experience base, but capture the cost advantages inherent to larger size solar cells.

AP-6105/AP-7105 modules utilize industry standard construction techniques to ensure long life even in the most severe environments. Every module is covered by a comprehensive twenty year warranty, and meets all applicable industry and consumer standards for safety and reliability.

The lower cost and high performance of these modules makes them suited to an extremely wide range of PV applications. Conventional industrial systems such as telecommunication and navigation aids will benefit from the high performance and durability of this design. Price-sensitive applications such as rural electrification (water pumping, village power, home lighting systems, etc.) will benefit from the extra value which these modules afford without the need to compromise quality or performance.



## MODULE FEATURES

- Each module contains 36 series-connected single crystal silicon solar cells for optimum battery charging performance in hot weather or low light levels.
- Power output of 65-75 watts meets the range of greatest market demand.
- Over 4.0 amps of charging current in full sunlight.
- Heavy duty anodized frame provides strength and convenient mounting access.
- Module width and mounting hole pattern conform to industry standards – fits existing mounting racks and trackers.
- Weather resistant junction box, including protective diodes, allows for easy and safe field interconnection.
- UL Listed / IEC1215 / CEC503 / TÜV.
- Twenty year warranty.
- Also available in black frame/blue tedlar designed specifically to enhance the appearance of residential rooftop installations.



# ELECTRICAL/MECHANICAL CHARACTERISTICS

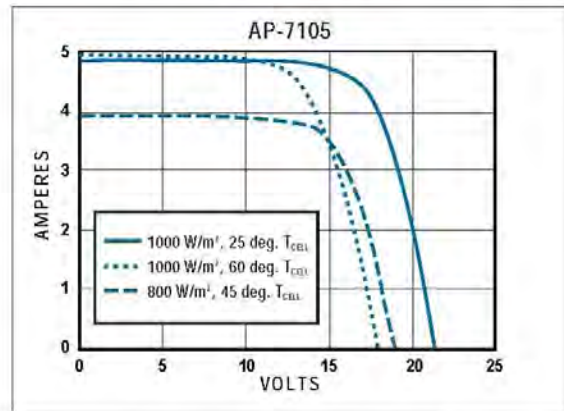
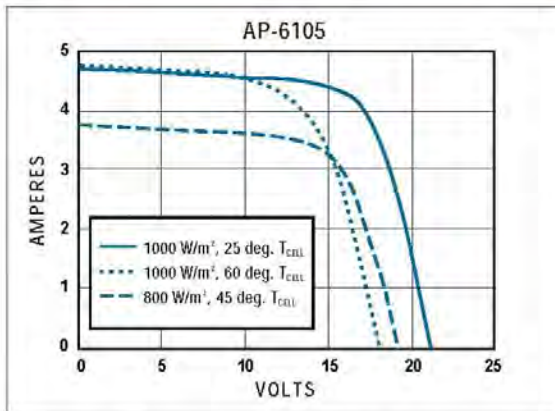

## TYPICAL ELECTRICAL/MECHANICAL PARAMETERS

Nominal Operating Cell Temp. (NOCT)	42°C (Determined under: Irradiance = 800 W/m²; ambient temperature = 20°C; wind speed = 1m/s)
Short Circuit Temp. Coefficient	+0.2mA/°C
Open Circuit Voltage Coefficient	-0.08 V/°C
Typical Fill Factor	69% (AP-6105)    74% (AP-7105)
High Voltage Standoff Potential	2200 Volts
Ground Continuity of Frame	< 1 ohm
Weight (Wind) Bearing Potential	50 lbs/ft² (125 mph equiv.) (2400 N/m² (200 kph equiv.))
Hailstone Impact Resistance	1" @ 50 mph (24 mm @ 80 kph)

## TYPICAL OUTPUT SPECIFICATIONS

Ⓜ Standard Test Conditions (defined as: Irradiance = 1000 W/m²; cell temperature = 25°C; solar spectral irradiance per ASTM E892 (air Mass = 1.5))

	AP-6105	AP-7105
Peak Power* (W <sub>p</sub> )	65 Watts	75 Watts
Open Circuit Voltage (V <sub>oc</sub> )	20.5 Volts	21.0 Volts
Max. Power Voltage (V <sub>mp</sub> )	16.3 Volts	17.0 Volts
Short Circuit Current (I <sub>sc</sub> )	4.6 Amps	4.8 Amps
Max. Power Current (I <sub>mp</sub> )	4.0 Amps	4.4 Amps
Weight	18.1 lbs. (8.2 kg)	
Dimensions	47.2 x 20.7 x 1.4 in. (1210.0 x 526.0 x 35.0 mm)	

\*rated power tolerance ±10%

## AP-6105/AP-7105 PHYSICAL SPECIFICATIONS

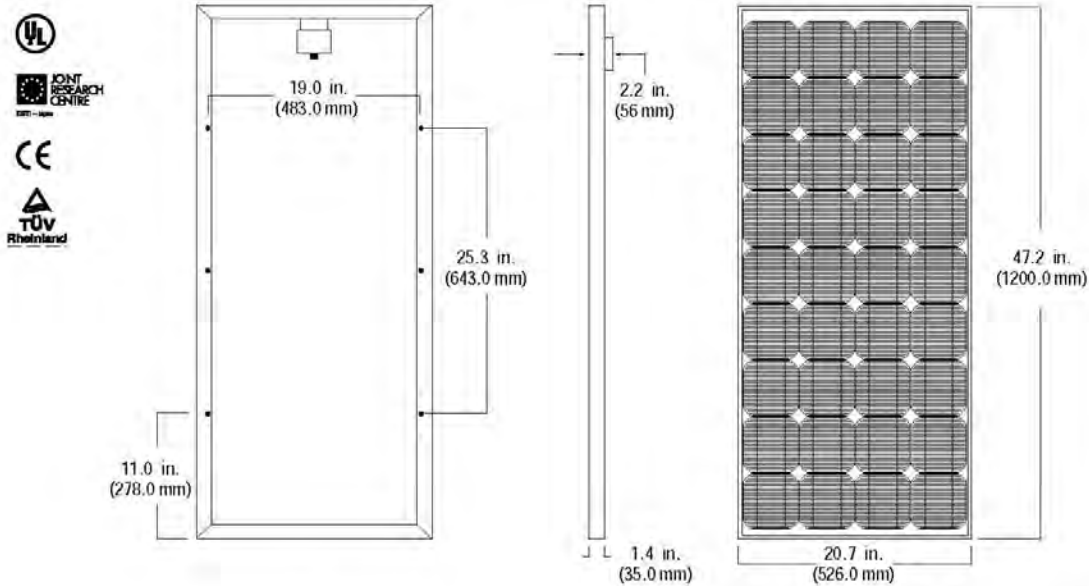

Note: Mounting hole diameter is .26" (6.6 mm).

4/99

**ASTROPOWER**  
BY BOBOMER

AstroPower, Inc., Solar Park, Newark, DE 19716-2000 USA  
tel 302-366-0400 fax 302-368-6474 www.astropower.com

THE NEW VALUE FRONTIER



KC MODULES | d.Blue Modules

### Kyocera Empowers Your Future

40-200 WATT POWER RANGE  
130-200 WATT MODULES FEATURE MULTI-CONTACT™ OUTPUT CABLES  
40-130 WATT MODULES FEATURE IP-65 JUNCTION BOX  
HEAVY-DUTY ANODIZED ALUMINUM FRAME  
25-YEAR POWER OUTPUT WARRANTY

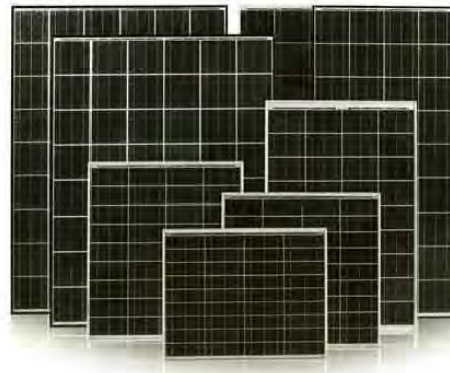

## SOLAR by KYOCERA

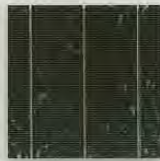

KYOCERA'S d.Blue technology is a process of texturing the surface of the solar cells to reduce reflection. This keeps more of the light energy within the cell, creating a gain in output power. The cell texturing and the new three-bus-bar electrodes combine to raise module performance to a new level.

### KYOCERA d.Blue Modules

KYOCERA has also gone from two bus bars per cell to three. By adopting three-bus electrode circuitry in combination with its "d.Blue" solar cell technology, KYOCERA has increased the power output of its solar modules by as much as seven percent without affecting the physical size of the modules. This gives the KYOCERA KC Module line a broad power range – from 40 watts to 200 watts – providing a solution for nearly every application.

d.Blue is ideal for installation on all types of buildings, from residential to large scale commercial systems. The stylish dark blue cells, combined with black module frames on the KC200GT, KC175GT and KC130GT, allow the modules to blend in with the buildings architecture while producing energy at exceptional efficiencies.

At the same time the higher power output of the new module line will save balance-of-system costs for all solar projects, from the smallest off-grid system to the largest industrial application.

## KC MODULES SPECIFICATIONS

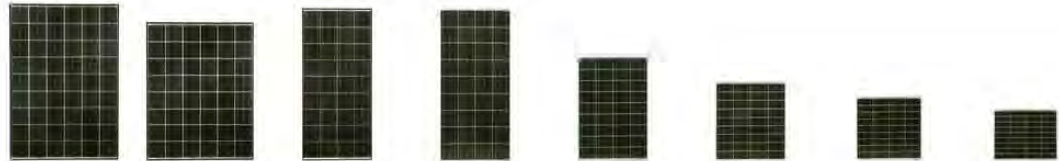

	KC200GT	KC175GT	KC130GT	KC130TM	KC85T	KC65T	KC50T	KC40T
Maximum Power	200W	175W	130W	130W	87W	65W	54W	43W
Tolerance	+10/-5	+10/-5	+10/-5	+10/-5	+10/-5	+10/-5	+15/-5	+15/-5
Maximum System Voltage	600V	600V	600V	600V	600V	600V	600V	600V
Maximum Power Voltage	26.3V	23.6V	17.6V	17.6V	17.4V	17.4V	17.4V	17.4V
Maximum Power Current	7.61A	7.42A	7.39A	7.39A	5.02A	3.75A	3.11A	2.48A
Open Circuit Voltage	32.9	29.2	21.9	21.9	21.7	21.7	21.7	21.7
Short Circuit Current	8.21	8.09	8.02	8.02	5.34	3.99	3.31	2.65
Length	56.2"	50.8"	56.0"	56.0"	39.6"	29.6"	25.2"	20.7"
Width	39"	39"	25.7"	25.7"	25.7"	25.7"	25.7"	25.7"
Depth	1.4"	1.4"	1.4"	2.2"	2.2"	2.1"	2.1"	2.1"
Weight	40.7 lbs	35.3 lbs	33.0 lbs	33.0 lbs	24.0 lbs	18.0 lbs	16.0 lbs	13.0 lbs
Warranty	25 Years	25 Years	25 Years	25 Years	25 Years	25 Years	25 Years	25 Years
Frame Color	Bronze Anodized	Bronze Anodized	Bronze Anodized	Clear Anodized	Clear Anodized	Clear Anodized	Clear Anodized	Clear Anodized
Termination Method	Plug-in Connectors	Plug-in Connectors	Plug-in Connectors	Conduit Ready Junction Box	Conduit Ready Junction Box	Conduit Ready Junction Box	Conduit Ready Junction Box	Conduit Ready Junction Box

Kyocera reserves the right to modify these specifications without notice.

All specification at 25°C, cell temperature, 1.5 AM and 1000W/m<sup>2</sup>  
 KC "TM" and "TM" modules have a conduit ready junction box. "GT" modules have multi-contact type connectors.

**KYOCERA SOLAR, INC.**  
 800-223-9580 toll-free  
 800-523-2329 fax  
[www.kyocerasolar.com](http://www.kyocerasolar.com)

© 2006 Kyocera Solar, Inc. All rights reserved.

## Chapter 8—Hull

The MWD Solar Cup is based on a one-class hull. This has been done to limit the burden on the participants and yet give significant freedom of design in several areas.

The hull, which has been chosen, has been named by its designers, “the 6-hour canoe”. Prior to 2002, it had only been paddled, but it had many desirable characteristics for use in Solar Cup. The hull has very good strength, lightweight, and exhibits very low drag at low speeds. It supports a great deal of weight; but of course, as the weight goes up, so does the drag. Although, it is a displacement hull, it was shown to work well with considerable power for Sprint competitions, although it never got “up on the step” and planed.

The rules require that the hull be used, essentially as originally designed, with the added strength of making the only frame into a full bulkhead. The skipper must be located forward of the bulkhead and the power train and batteries must be aft of it. By coating the plywood with epoxy, some weight is added but the strength of the plywood is greatly increased. This is far superior to reinforcing every point that is heavily stressed.

### CENTER OF GRAVITY

Before getting into some details, the significance of the layout needs to be addressed. The longitudinal center of gravity (cg) is very important. If the cg doesn't remain relatively fixed, the plane of the drive shaft will change and performance will change as well. Since there are no restrictions on 1) the position of the skipper in the forward half of the hull, 2) on the position of the batteries aft, and 3) the leeway of positioning any ballast as desired, testing has shown the hull to be rather forgiving for the distribution of weight.

It is important to consider the position of flotation in the overall layout. During testing, there should be adequate flexibility so that flotation is finalized after the ideal position for the skipper is determined. The same is true for steering. If the position of the steering “wheel” is established too early, it may not be possible to reposition the skipper as desired.

### STABILITY

The one thing that has been experienced is some difficulty steering if any of the bow stem is under the waterline. This **is not likely to occur but should be kept in mind**. When addressing the issue of the correct cg, be sure to take into account the position and weight of the solar panels. Their weight and the difference in power between the two configurations of the boat can change the cg very significantly.

### FINISHING THE HULL

The hull is fabricated out of a shingle sheet of ¼” thick marine plywood and each 16’ long sheet originally had one or two joints in it. Once the hull is fully assembled, the plywood is well supported by the chines and gunwales but it is important to remember it is only ¼” thick material. The first step in strengthening it is to coat it with epoxy. The first coat should be

spread with a 4" wide Joint Knife, sometimes known as a putty knife. An inexpensive plastic one is highly desirable, as dry epoxy does not stick to it. Mix the epoxy in relatively small batches; pour on to one surface at a time and spread, minimizing any excess. Then, with a 1" disposable brush, coat all corners and smaller parts such as chines, gunwales and stems.

### **AVOID PUDDLING.**

Allow to set up 24 hours if possible. Sand lightly between coats to remove high spots. A sanding block needs to be used on large flat areas. It should not be used where the epoxy was applied with a brush. Those must be done by hand with a "pad" of sandpaper. Take care not to sand through this coat. A second coat of epoxy should be applied. The smoothness of the final finish is dependant on the sanding between coats. A different technique is used for applying the second coat. A foam roller should be used; 3" or 4" is suggested. As with the first coat, use a brush in corners and for the chines and stems, etc. Cut a 9" short nap paint roller, which is designed for epoxy, in half with a saw. You will now have two pieces, each 4 1/3" long. These need to be cut lengthwise to make four curved "pads". After the fresh epoxy is applied, smooth immediately with a pad. If the wood is left natural, a protective UV blocking finish, such as varnish, should be added, as epoxy is sensitive to UV. Again, sand between coats whether the final finish is varnish or paint.

Since there is only one frame in the boat, the bottom of the bulkhead has been doubled so that the bottom can be secured to over 1 1/2 " of material. This is sufficient to carry the weight of the skipper and of the batteries. The 1/4" thick material **will not be sufficient** to carry the load of the motor, motor mount and the drive shaft. **Some provision will have to be made to reinforce this area of the bottom.** Commonly, there will be a bottom "plate" to the motor mount that will spread the load.

The last mount that will be very dependent on the hull strength will be the mounting for the rudder. **Experience has shown that the forces on rudders are often grossly underestimated.** This subject is addressed in the section on steering but that does not get into the associated hull strength issues.

### **SO WHAT ARE YOUR OPTIONS?**

If you feel that the hull needs added stability, you are free to add appendages to the exterior, as long as they do not exceed the allowed outside dimensions of the boat. On the inside, there are no restrictions on what you can do to create the configuration you desire.

The remaining area, which has not been discussed, is the vertical position of the cg. The higher the cg, the tippier the boat will be. Certainly, the skipper and batteries can be on or very close to the floor. The single biggest element, which is likely to affect the cg, is your solar array. Since this must be above the gunwales, it significantly raises the cg for the Endurance configuration. When planning your array, be sure to take this into account.

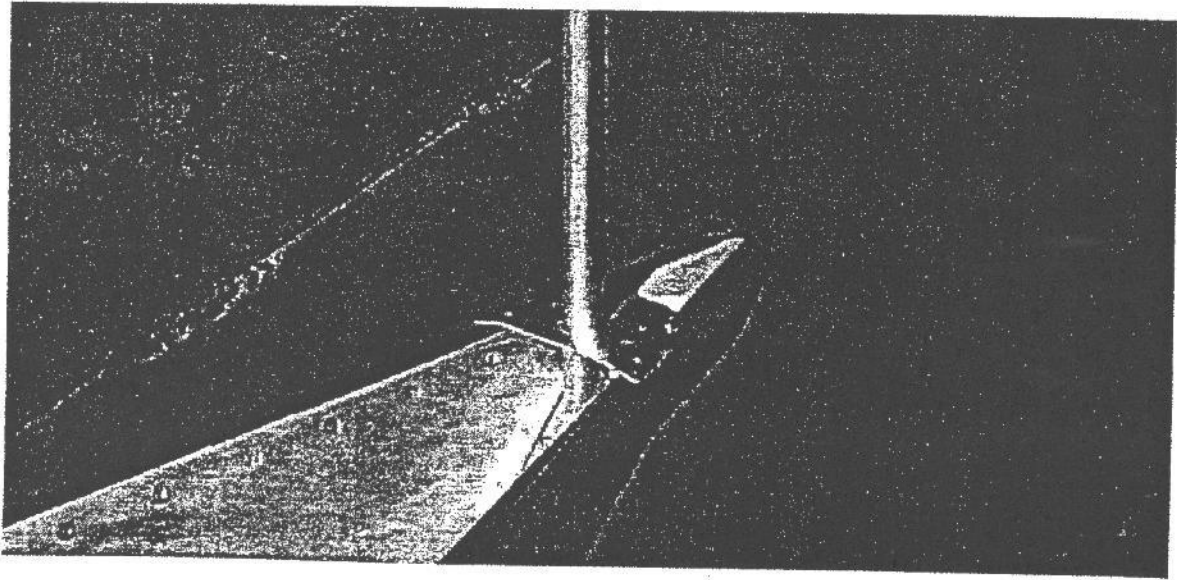

The Boat Sign Base attaches to the stern stem and to the gunwales with screws.



There is a special type of roller used for epoxy. This brand is available at Home Depot.

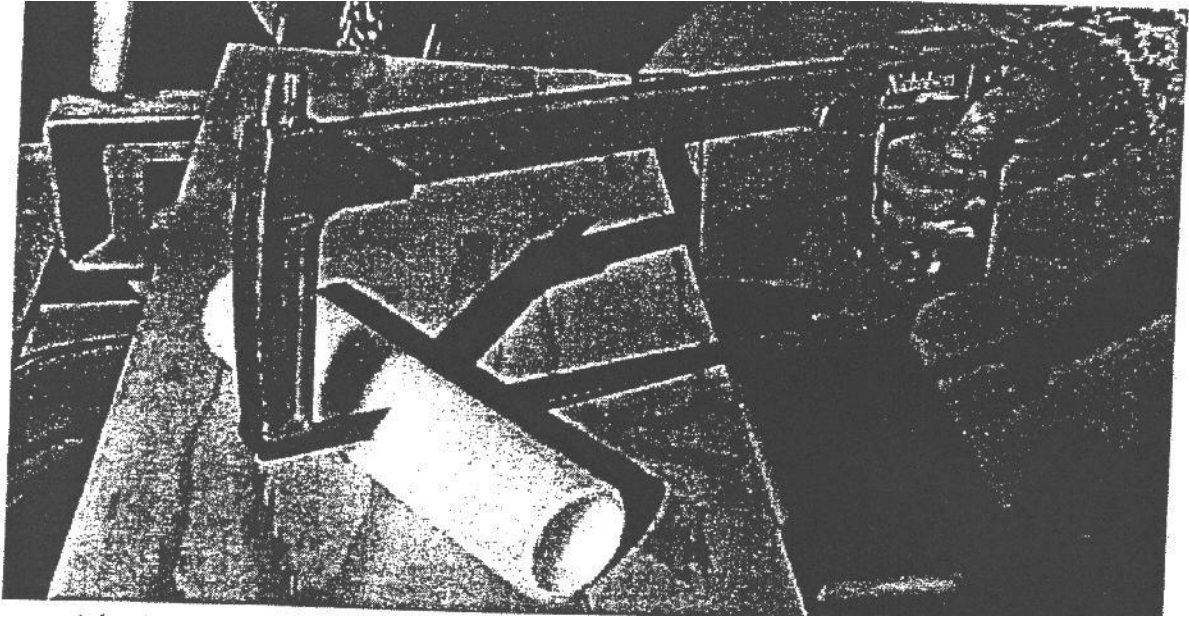

A hacksaw or power saw can be used to cut the 9" roller into 4" lengths which are much more manageable in size.

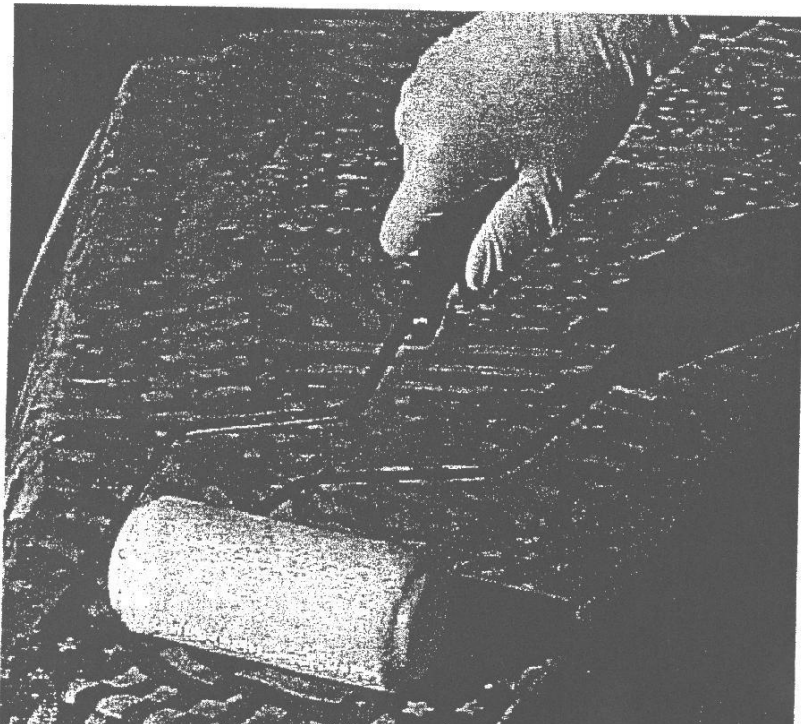

It is suggested that you pour a small batch of epoxy, not more than two pumps, on to the surface and spread with the 4" roller.

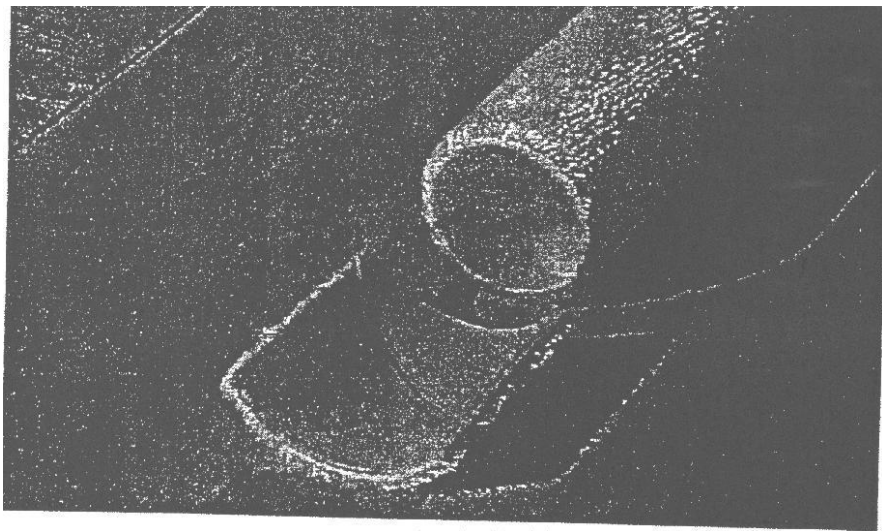
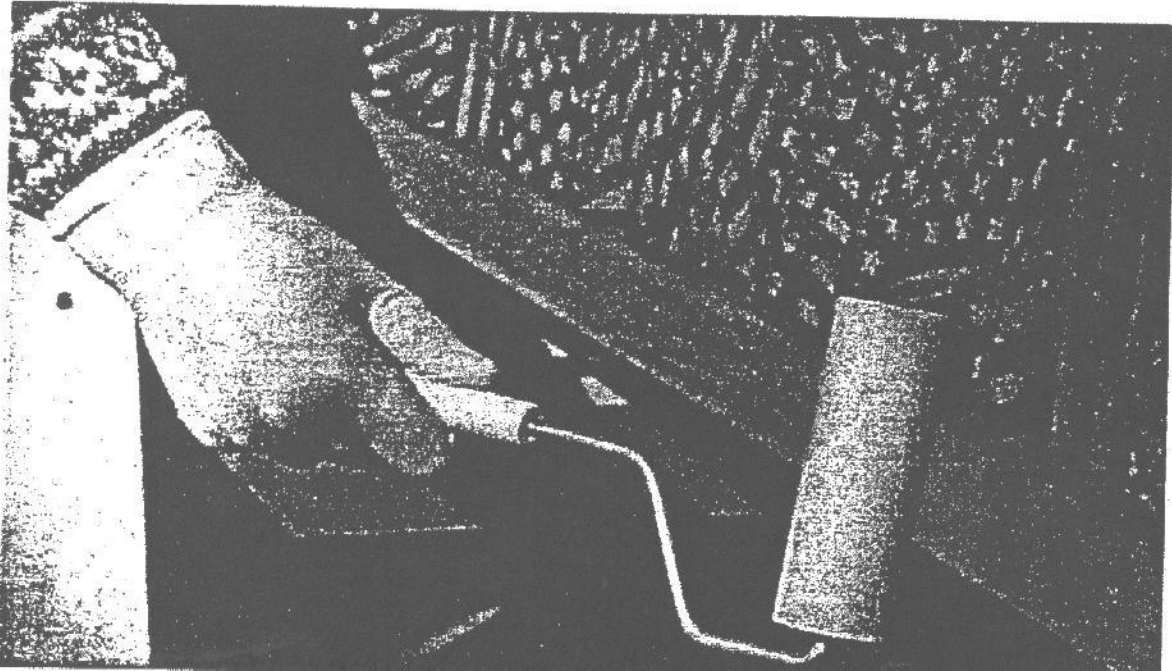

You will need to cut an applicator roller to make “spreaders” to be used once the epoxy is applied with the roller. First, cut the roller into 3” sections, and then cut each one in half, along the 3” axis. Clean off any loose fuzz.

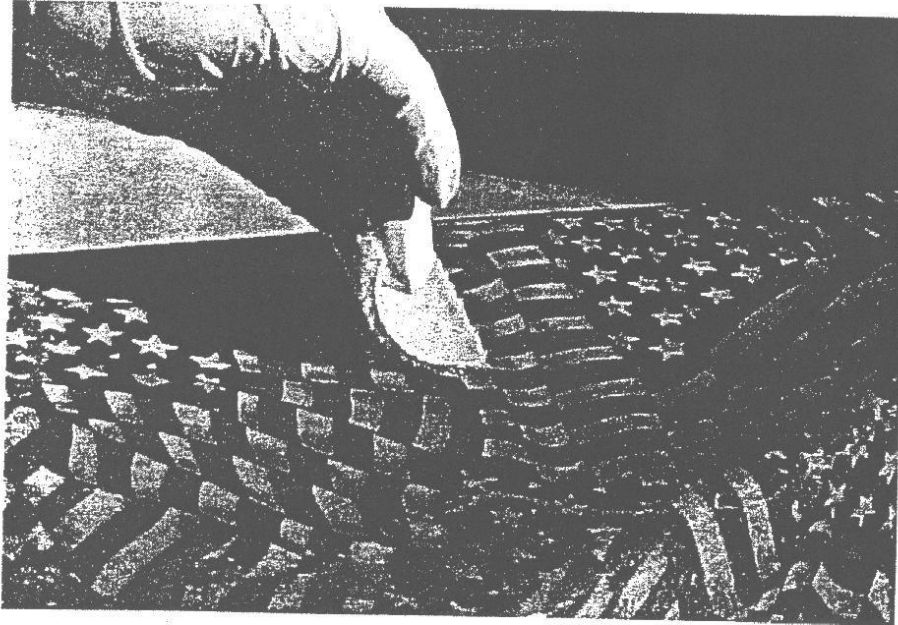

Although the roller does a good job of distributing the epoxy, the surface is not smooth. Use a spreader in long strokes to smooth the surface.

# Chapter 9—Flotation

## FLOTATION CALCULATIONS

	Weight (lbs)
Batteries and boxes	48
Drive Train	25.5
Steering	6.5
Rudder	6
Wires	6.5
Throttle Assembly	2
Motor and Controller (mounted to Plate)	47.5
Battery Plate and Assorted Hardware	10
<hr/>	
	152
<b>Total non-buoyant weight</b>	152
<b>Displacement needed with 20% margin</b>	182.4
<b>Displacement needed / 62 lbs per ft (3)</b>	2.95

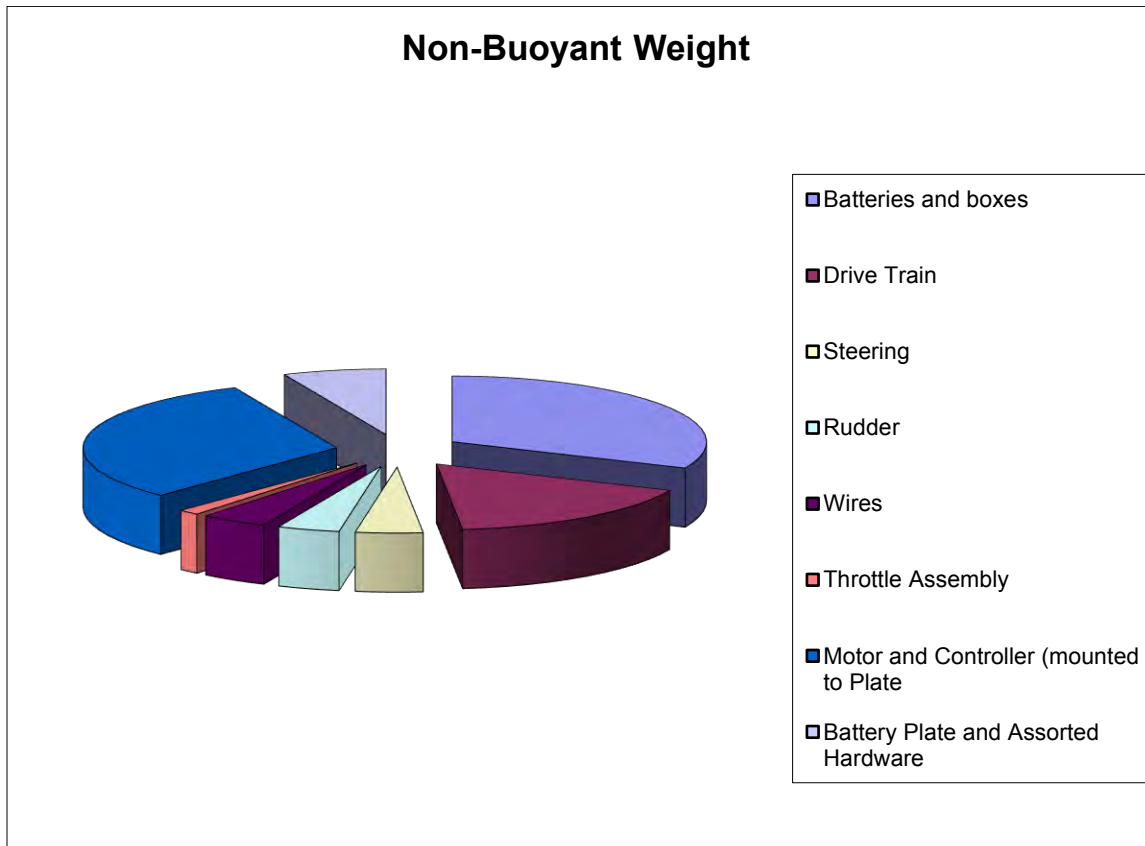

As you can see, we need a little under three cubic feet of foam. When we placed the foam in our boat, we actually put in around three and a half cubic feet of foam.

## FLOTATION

We do not want to lose any boats and we do not want to litter the lake. Therefore, there is a requirement for the boat to have enough flotation, with a safety factor of 20%, to float if it capsizes. Before we get into how to do the calculation, let us address what does not go into it. It is assumed that the skipper will be floating with the aid of the life jacket so the skipper weight is not included. It is also assumed that the ballast bag(s) will fall out and sink to the bottom.

So, you need to show that the weight of all components with a 20% safety factor is equal or less than the flotation. You may not show that the displacement proves that the boat will float.

Because the boat is made of wood, it will float. Adding epoxy seals the wood but adds weight. We assume the boat will float but not contribute significantly to the overall flotation. Add up the weight or your best estimate of each component whether it is lighter or heavier than its volume of water. Add 20%. Calculate the volume of flotation material in cubic feet. That figure x 62-lbs/cubic ft. must exceed the weight of the boat components.

The less the weight of the flotation, the less volume is needed. Therefore, an air chamber is the most efficient way of providing flotation. One of the possible options is to add a small bulkhead, aft of the bow, and seal it with a top. This may slightly limit space for the skippers' toes but should not be a problem. This can be done using relatively thin plywood, 1/8", fiberglass cloth and epoxy. It is likely you will need more volume.

Another way to do this is to use air bladders or "pillows". These are commercially available in various sizes and shapes. They can be lashed in place and easily removed. The drawbacks are cost, and space. They will not conform exactly to the shape of the hull and thus valuable space will not be lost. BUT, you may want to consider more than one method such as an air chamber in the bow and removable flotation somewhere in the aft section of the boat.

Optionally, there are a variety of plastic foam materials that can be used. If you want to shortcut the sealed air chamber, you can make a rough bulkhead and then pour two-part foam into it, trimming off the excess. This is quick but may not add to the visual appearance in a positive way. The foam adds a little weight, so slightly more volume is required. **Experience has shown that the single most effective way of adding 50% or more of the needed flotation is to get a large block of Styrofoam and shape it to fit just forward of the bulkhead. It may also serve as a backrest for the skipper. This material can be painted with a particular spray paint made for the purpose or may be covered with any number of materials. Shaping and joining of pieces is easy, there is a special adhesive for that purpose.**

The solar panels are another site where flotation may be added. Sheet foam is available in many thicknesses and could be cut and secured to the back of each panel but this will not add flotation for the Sprint configuration.

These are just some thoughts. At a later date, the due date for flotation calculations will be announced and will have to be submitted for approval. **This is mandatory.**

## THINGS THAT WILL NOT FLOAT ON THE BOAT

- Large Batteries: 22 lbs. 3.75 oz. (2)  
 $22 \text{ lbs.} + .2 \text{ lbs.} = 22.2 \text{ lbs.} * 2 \text{ lbs.} = 44.4 \text{ lbs.}$
- Small Battery: 5 lbs. 13 oz.  
 $5 \text{ lbs.} + .8 \text{ lbs.} = 5.8 \text{ lbs.}$
- Motor: 12 lbs. 1.50 oz.  
 $12 \text{ lbs.} + .1 \text{ lb.} = 12.1 \text{ lbs.}$
- Fire Extinguisher: 2 lbs. 12 oz.  
 $2 \text{ lbs.} + .6 \text{ lbs.} = 2.6 \text{ lbs.}$
- Paddle: 10 oz.  
.6 lbs.
- Bottom of the seat: 1 lb. 13 oz.  
 $1 \text{ lbs.} + .8 \text{ lbs.} = 1.8 \text{ lbs.}$
- Bilge Pump: 1.5 lbs.  
1.5 lbs.
- Solar Panels: 3 lbs. 12 oz. (10)  
 $3 \text{ lbs.} + .8 \text{ lbs.} = 3.8 \text{ lbs.} * 10 \text{ lbs.} + 38 \text{ lbs.}$
- Aluminum Sheet: 5 lbs. 2 oz.: 6.5 lbs., 1 lb., 9 oz., .5 lbs. (tubing), .5 lbs. (pedals)  
 $6.5 \text{ lbs.} + 1 \text{ lb.} + .6 \text{ lbs.} + .5 \text{ lbs.} + .5 \text{ lbs.} = 9.1 \text{ lbs.}$
- Propeller: 10 oz.  
.6 lbs.
- Battery Cases (2)  
 $1 \text{ lb.} + 1 \text{ lb.} = 2 \text{ lbs.}$
- Solar Panel Frames and Stands: 10.3 lbs.  
10.3 lbs.

Total Amount of Weight: 128.8 lbs.

$$\text{Total Amount of Weight: } \frac{128.8 \text{ lbs.}}{1} * \frac{1 \text{ cb ft.}}{62.4 \text{ lbs}} = 2.06 \text{ cf} * 1.20 = 2.5 \text{ cf}$$



# Chapter 10—Motor

DC motors come in a variety of types, each with its own unique set of characteristics. The most common types of DC motors are:

- Permanent magnet
- Shunt wound
- Series wound
- Compound wound
- Brushless

Each of these motors has its own set of advantages and disadvantages when compared to the other types. An in-depth discussion of motor theory can be found at:

<http://www.reliance.com/mtr/mtrthrmn.htm>

Table 1 below gives a brief comparison of the relative strength and weaknesses of these different DC motor types.

DC Motor Type	Strengths	Weaknesses
Permanent Magnet	No field winding, good starting torque, high efficiencies possible	Has brushes, speed control not as easy as shunt
Shunt Wound	Good speed regulation	Has brushes, low starting torque
Series Wound	Good starting torque	Has brushes, poor speed control, runs away under no load
Compound Wound	Combines strengths of series and shunt wound	Has brushes, more complex, heavier
Brushless	No brushes, very high efficiencies possible	Speed control is complicated, not readily available in as many sizes

Table 1. A comparison of DC motor types.

In order to compare the characteristics of these motor types, it is necessary to understand how to read a set of motor characteristic curves. Motor curves, available from the manufacturer, are plots of voltage, current, torque, speed, power, and efficiency. Figure 1 shows a set of motor curves for a permanent magnet motor.

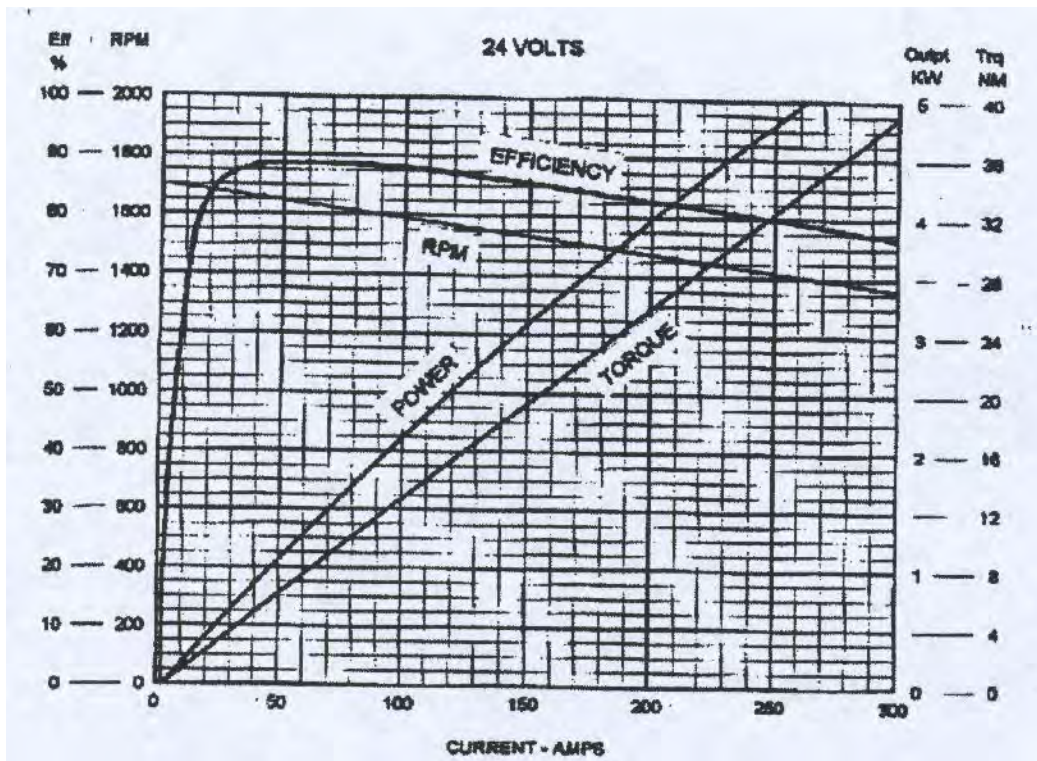

Figure 1. Motor characteristics curves for a permanent magnet DC motor at 24 V.

Quite a bit of information is shown in Fig. 1 if one understands how to read the curves. First, note that all four of the curves are plotted against current. (Some manufacturers may generate motor curves using torque as the independent variable.) Second, note that the curves are generated for a motor voltage of 24 volts.

Efficiency is often a good starting place both for comparing motors and for determining the suitability of a particular motor for the Endurance event. This motor has its peak efficiency of 89% at a current of approximately 60 amps, but the efficiency is close to the peak value for a range of 30 to 120 amps. / Increasing the current level above 120 amps causes a gradual decrease in efficiency, but the efficiency drops off rapidly for currents less than 30 amps.

The operating current of the motor will be determined by the amount of power available from batteries and solar panels. The current level for the Endurance event can be substantially different from the current level used in the Sprint event. The following example is an illustration of how to read the information on a set of motor characteristics curves.

Example: If a current level of 50 amps is chosen, Fig. 1 shows that the motor will be Running at an efficiency of about 89%, at a rotational rate of 1650 rpm, producing a Torque of about 6 Newton-meters (Nm), and producing an output power of about 1.1 kW.

The rotational rate can be used to determine “gearing”, if any, required to give a desired propeller rotational rate. The torque and power values should be used to select proper shaft size and for other drive train considerations.





**Briggs & Stratton is renowned worldwide for leadership in power technology.**

You have counted on our gas engines for performance, power, reliability, and profitability. Now, you can get those same benefits from our Elek™ Electric Motor System. An innovative product in battery powered equipment.

Do not let the small size fool you. The uniquely integrated Elek™ system provides a highly efficient combination of hardworking power and torque. Compared to other DC motor systems, the Elek™ system reduces maintenance costs, uses less energy and offers a longer operating life. All in a smaller, lighter weight design.

The compact size, 50% smaller and 20 lbs. lighter than other motors, results in a high power-to-weight ratio. You get high torque at low speeds and longer run life between charges.

**SAFETY**

-  The safety alert symbol is used to identify safety information about hazards which can result in death, serious injury, and/or property damage.
-  **WARNING** indicates a hazard which, if not avoided could result in death or serious injury.
-  **CAUTION** indicates a hazard which, if not avoided might result in death or serious injury.
- CAUTION** when used without the alert symbol, indicates a situation that could result in damage to the motor.

**HAZARD SYMBOLS AND MEANINGS**

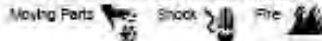

**WARNING**



**Electrocution or serious injury can occur if proper precautions are not followed.**

- DO NOT pour or spray water on the motor while running or cleaning.
- DO NOT attempt to repair or make adjustments to the motor while in operation.
- Keep the motor clean of grass, chaff and dirt. An accumulation of combustible material around or on the motor will prevent cooling and may result in a fire, and personal injury.

**WARNING**



**Rotating parts can contact or entangle hands, feet, hair, clothing, or accessories. Traumatic amputation or severe laceration can result.**

- Operate unit with guards in place.
- Keep hands and feet away from rotating parts.
- Tie up long hair and remove jewelry.
- Do not wear loose-fitting clothing, dangling drawstring or items that could become caught.

**FEATURES**

Motor provides 32 ft-lbs of torque independent of vehicle voltage. Maximum speed is self regulating and is set by the manufacturer to meet specific application requirements. Improved regenerative braking can be set to meet terrain requirements and individual needs for "feel". Reduces brake wear and enhances battery life.

- Axial air gap DC disc armature motor means a lot of power in a small package.
- Permanent magnet field provides high efficiency and minimal loss of speed as motor increases.
- Reliability and rugged construction, with no commutator connections, reduce maintenance costs and extend motor life.
- High power-to-weight ratio due to compact disc construction and integral commutator.
- Lightweight aluminum frame.



**GENERAL INFORMATION**

- Voltage Constant: 72 RPM per Volt
- Torque Constant: 1.14 in lb/Amp (0.13 Nm/Amp)
- Maximum Motor Current: 330 amps for 1 minute
- Motor Weight: 21 lbs.
- Motor Output: Maximum 15 Hp, 6 Hp continuous
- Maximum Motor Voltage: 48 V D.C.
- Maximum No Load Current: 6 Amp

**OPERATION**

In tests, the Briggs & Stratton Elek™ motor outperformed the competition by maintaining consistent speed and optimal efficiency across a wide range of loads.

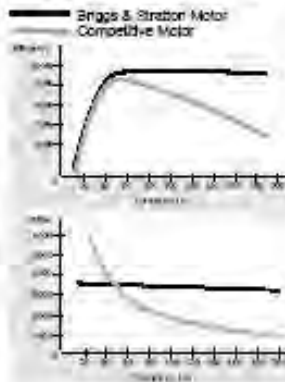

## APPLICATION



### WARNING

Briggs & Stratton does not approve or authorize the use of this motor on 3-wheel All Terrain Vehicles (ATVs), motor bikes, aircraft products or vehicles intended for use in competitive events. Use of this motor in such applications could result in property damage, serious injury (including paralysis), or even death.

### WARNING



#### Battery post can explode.

- Keep sparks and flames away from batteries.
- Never place a metal object across battery posts to check for charge - use a voltmeter or hydrometer.
- Keep battery post and electrical connection covers in place.

### WARNING



Ensure proper battery capacity for the desired output.

- Do not use battery pack voltages above 48 volts.
- Never connect motor directly to battery power without the use of a contactor(s) and/or electronic controller.
- Batteries develop extremely high currents; use precaution.

### WARNING



Briggs & Stratton recommends the use of overcurrent protection when applying this motor. Use of properly sized fuses and/or breakers are recommended.

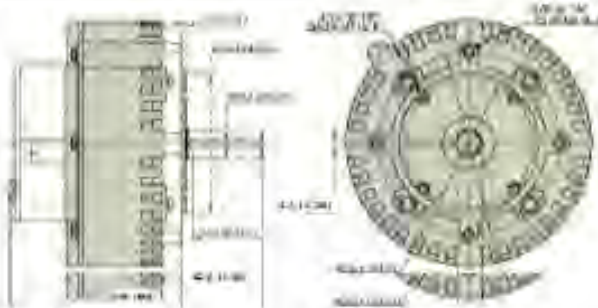

## MAINTENANCE



### WARNING



Batteries can develop extremely high currents. Motor removal, or brush housing replacement should be done by a qualified technician.

#### DEBRIS CLEANING

Periodically remove grass, chaff or dirt around the air cooling vents of the frame to prevent overheating of the motor.

#### BRUSH INSPECTION

Yearly or every 100 hours have brushes inspected for wear. Replacement of brush housing is recommended when brush length is at 1/8" above brush holder. Torque brush cover bolts to 8.8 in. lbs.

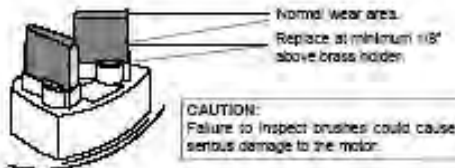

## SERVICE



The Briggs & Stratton Elen™ motor is so durable and efficient, we are only offering the brush pack as a service item.

Brush housing To order use:  
P/N 898852, includes complete brush set along with cover pin (898953), bolts and washers.

### WARNING

DO NOT disassemble the motor. Voltage and output have been pre-set by the factory. Any tampering with the magnet settings may cause serious damage to the motor.

To obtain replacement parts, you may locate your nearest Authorized Briggs & Stratton Service Dealer in our dealer locator map on our web site [www.briggsandstratton.com](http://www.briggsandstratton.com) or in the



"Yellow Pages" directory under "Engines, Gasoline" or similar category.

Briggs & Stratton Motor Technology is featured from Lynch (P) under U.S. Patent No. 4,923,024 and PCT Patent Application No. PCT/US94/02101.

## ABOUT YOUR ENGINE WARRANTY

Briggs & Stratton welcomes warranty repair and applications to you for being inconvenienced. Any Authorized Service Dealer may perform warranty repairs. Most warranty repairs are handled outside, but sometimes repairs for warranty service may not be appropriate. For example, warranty would not apply if engine damage occurred because of misuse, lack of routine maintenance, dropping, handling, weathering or improper installation. Similarly, warranty is void if the serial number of the engine has been removed or the engine has been altered or modified.

If a customer differs with the decision of the Service Dealer, an investigation will be made to determine whether the warranty applies. Ask the Service Dealer to submit all supporting facts to its Distributor or the Factory for review. If the Distributor or the Factory decides that the claim is justified, the customer will be fully reimbursed for those items that are defective. To avoid misunderstanding which might occur between the customer and the Dealer, please follow some of the causes of engine failure that the warranty does not cover:

**Misuse:** Engines are all mechanical devices, need periodic parts service and replacement to perform well. Warranties will not cover repair when misuse has exhausted the life of a part or an engine. **Appropriate maintenance:** The life of an engine depends upon the conditions under which it operates, and the care it receives. Some applications, such as lawns, pumps and rotary mowers, are very often used in dusty or dry conditions, which can cause what appears to be premature wear. Such wear, when caused by dirt, dust, spark plug cleaning gel, or other abrasive material that has entered the engine because of improper maintenance, is not covered by warranty.

This warranty covers engine related defective material under normal warranty only, and not replacement or refund of the equipment to which the engine may be installed. Nor does the warranty extend to repairs required because of:

1. PROBLEMS CAUSED BY PARTS THAT ARE NOT ORIGINAL BRIGGS & STRATTON PARTS.
2. Equipment controls or malfunctions that prevent starting, cause unsatisfactory engine performance, or shorten engine life. (Contact equipment manufacturer.)
3. Leaking customers, clogged fuel pipes, clogging valves, or other damage, caused by using contaminated or stale fuel. (See dealer, Tech, lead-free gasoline and Briggs & Stratton gasoline radiator, Part No. 5341.)
4. Parts which are scored or broken because an engine was operated with insufficient or contaminated lubricating oil, or an incorrect grade of lubricating oil (used oil level daily or after every 8 hours of operation. Add when necessary and change at recommended intervals.) OIL (GRADE) may not shut down running engine. Engine damage may occur if oil level is not properly maintained. Read Operating & Maintenance Instructions.
5. Repair or adjustment of associated parts or assemblies such as switches, transmissions, remote controls, etc., which are not manufactured by Briggs & Stratton.
6. Damage or wear to parts caused by dirt, which entered the engine because of improper air cleaner maintenance, re-assembly, or use of a non-original air cleaner element or cartridge. (At recommended intervals, clean and re-oil the OIL Famy element or the foam pre-cleaner, and replace the cartridge.) Read Operating & Maintenance Instructions.
7. Parts damaged by overloading, or overworking caused by grass, sticks, or dirt which plugs or clogs the cooling fan, or flywheel area, or damage caused by operating the engine in a confined area with out sufficient ventilation. (Clear fans on the flywheel, flywheel head and flywheel at recommended intervals.) Read Operating & Maintenance Instructions.
8. Engine or equipment parts broken by excessive vibration caused by a loose engine mounting, loose outer blades, unbalanced blades or loose or unbalanced impellers, improper attachment of equipment to engine crankshaft, overloading or other abuse in operation.
9. A bent or broken crankshaft, caused by striking a solid object with the outer blade of a lawnmower, or excessive wheel tightness.
10. Routine tuning or adjustment of the engine.
11. Engine or engine component failure, i.e., combustion chamber, valves, valve stems, valve guides, or bent/damaged piston rings, caused by the use of alternate fuels such as, liquefied petroleum, natural gas, ethanol gasoline, etc.

## BRIGGS & STRATTON OWNER WARRANTY POLICY effective July 1, 2001

### LIMITED WARRANTY

Briggs & Stratton Corporation will repair or replace, free of charge, any part, or parts of the engine that are defective in material or workmanship or both. Transportation charges on parts submitted for repair or replacement under this Warranty must be borne by purchaser. This warranty is effective for the time periods and subject to the conditions stated herein. For warranty service, find the nearest Authorized Service Dealer in our dealer locator map at [www.briggsandstratton.com](http://www.briggsandstratton.com) or as listed in the "Yellow Pages"™ under "Engines, Gasoline" or similar category.

THERE IS NO OTHER EXPRESS WARRANTY, IMPLIED WARRANTIES, INCLUDING THOSE OF MERCHANTABILITY AND FITNESS FOR A PARTICULAR PURPOSE, ARE LIMITED TO ONE YEAR FROM PURCHASE, OR TO THE EXTENT PERMITTED BY LAW ANY AND ALL IMPLIED WARRANTIES ARE EXCLUDED. LIABILITY FOR CONSEQUENTIAL DAMAGES UNDER ANY AND ALL WARRANTIES ARE EXCLUDED TO THE EXTENT EXCLUSION IS PERMITTED BY LAW. Some countries or states do not allow limitations on how long an implied warranty lasts, and some countries or states do not allow the exclusion or limitation of incidental or consequential damages, so the above limitations and exclusion may not apply to you. This warranty gives you specific legal rights and you may also have other rights which vary from country to country and state to state.

Products	WARRANTY PERIOD*			
	WITHIN U.S.A. AND CANADA		OUTSIDE U.S.A. AND CANADA	
	Consumer Use	Commercial Use	Consumer Use	Commercial Use
Vanguard™ engines.	2 years			
Diamond Power®, Industrial Plus™, PCR, Sierra Snow Intek™, and ELS™ engines.	2 years	1 year	2 years	1 year
Quantum®, Diamond Power®, Kool Bore Intek™, and Power Built™ OHV engines.	2 years	90 days	2 years	90 days
Standard engines installed on lawn mowers, riders, edgers, choppers, shredders, string trimmers, tillers and Sno-Gard engines.	2 years	90 days	1 year	90 days
Classic™ engines and all other standard engines and products.	1 year	90 days	1 year	90 days
Elek™ electric motor.	1 year			

\* NOTE THE FOLLOWING SPECIAL WARRANTY PERIODS: 5 years for consumer use, 90 days for commercial use of ToughMax™ starter on the Quantum® and Intek™ engines. 2 years for emission control systems on engines certified by EPA and CARB. 1 year for consumer use of all engines and products in India, commercial use of Vanguard™ engines in India, and consumer use of Quantum Diamond Power™ and Kool Bore Intek™ engines in Australia, New Zealand, the Middle East, and Africa.

The warranty period begins on the date of purchase by the first retail consumer or commercial end user, and continues for the period of time stated in the table above. "Consumer use" means personal residential household use by a retail consumer. "Commercial use" means all other uses, including use for commercial, income producing or rental purposes. Once an engine has experienced commercial use, it shall thereafter be considered as a commercial use engine for purposes of the warranty. Engines used in competitive racing or on commercial or rental vehicles are not warranted.

NO WARRANTY REGISTRATION IS NECESSARY TO OBTAIN WARRANTY ON BRIGGS & STRATTON PRODUCTS. SAVE YOUR PROOF OF PURCHASE RECEIPT IF YOU DO NOT PROVIDE PROOF OF THE INITIAL PURCHASE DATE AT THE TIME WARRANTY SERVICE IS REQUESTED. THE MANUFACTURE DATE OF THE PRODUCT WILL BE USED TO DETERMINE THE WARRANTY PERIOD.

Briggs & Stratton Engines Are Made Under One Or More Of The Following Patents: Design D-347,177 (Other Patents Pending)

8,136,420	8,023,653	5,819,645	5,487,079	5,197,425	5,083,880	4,895,267	4,694,732	4,490,994	083,328,450
8,118,210	8,019,513	5,800,948	5,329,795	5,197,422	5,070,626	4,877,079	4,684,917		083,328,427
8,077,083	8,013,364	5,800,951	5,271,363	5,191,864	5,069,644	4,871,219	4,633,596		083,328,071
8,064,027	8,009,959	5,549,935	5,286,710	5,198,385	5,043,933	4,856,119	4,638,488		083,328,072
8,046,787	8,005,713	5,549,931	5,285,330	5,196,142	5,043,644	4,855,648	4,622,389		083,328,061
8,014,008	8,002,025	5,550,125	5,243,076	5,198,990	5,039,208	4,849,083	4,628,290		083,361,771
8,004,716	8,002,701	5,551,220	5,238,940	5,198,351	4,989,858	4,719,040	4,603,507		083,335,880

## MOSFET ELECTRONIC MOTOR SPEED CONTROLLERS

MODEL 1204/1204S/1205



CURTIS



### DESCRIPTION

Curtis PMC Models 1204/1204S/1205 are power MOSFET electronic motor speed controllers designed to provide smooth, silent, efficient and cost effective speed, torque and braking control.

### APPLICATION

Curtis PMC MOSFET motor speed controllers are ideal for a variety of electric vehicle applications, including industrial trucks, personnel carriers, material handling vehicles and golf cars, etc.

### FEATURES

- High frequency switching and ultra low voltage drops provide very high efficiency and silent operation. Costs, heatsinking requirements and motor and battery losses are reduced. Low end torque, range and battery life are increased.
- Environmental protection provided by a rugged anodized aluminum extrusion housing. Simple mounting and wiring with push-on type connectors for control signals. Plated solid copper busses used for all power connections.
- Thermal protection and compensation circuit provides constant current limit over operating range and under temperature and over temperature cutback. No sudden loss of power under any thermal conditions.
- No adjustments are required.
- Simple installation — Uses a two wire throttle potentiometer.
- Potentiometer fault protection circuitry disables controller if throttle wires become open.
- High pedal disable prevents controller operation if key is turned on while throttle is applied.
- Plug braking diode internal to controller.

### SPECIFICATIONS

- Frequency of Operation: 15 kHz
- Standby Current: less than 20 mA
- Standard Throttle Input: 0-5k ohms  $\pm$ 10% (others available)
- Weight: 1204/1204S: 1.8 kg (4 lbs);  
1205: 2.7 kg (6 lbs)
- Full Power Operating Temperature Range:  
-25°C to 75°C (controller temperature)

#### CURTIS INSTRUMENTS, INC.

200 KISCO AVENUE  
MT. KISCO, NY 10549  
USA  
TEL (914) 666-2971  
FAX (914) 666-2188

235 EAST AIRWAY BLVD.  
LIVERMORE, CA 94551  
USA  
TEL (925) 961-1088  
FAX (925) 961-1099

#### CURTIS INSTRUMENTS, (UK) LTD.

5 UPPER PRIORITY STREET  
NORTHAMPTON NN1 2PT  
ENGLAND  
TEL 44 (0) 1604-629755

#### CURTIS INSTRUMENTS INDIA PRIVATE LTD.

1199, GHOLE ROAD  
PUNE 411004, INDIA  
TEL 91 (0) 20-5531288  
FAX 91 (0) 20-5539192

[www.curtisinstruments.com](http://www.curtisinstruments.com)

## MODEL 1204/1204S/1205

### MODEL CHART

CURTIS PMC MODELS	VOLTAGE (volts)	CURRENT (amps)	2 MIN RATING (amps)	5 MIN RATING (amps)	1 HOUR RATING (amps)	VOLTAGE DROP @ 100A	UNDERVOLT CUTBACK (volts)
1204-0xx	24-36	275	275	200	125	0.35	16
1204-1xx	24-36	175	175	130	75	0.50	16
1204-4xx	36-48	275	275	200	125	0.35	21
1204S-5dxx	36-48	450	450 (30 sec)	300	150	0.25	21
1204-6xx	12	275	275	200	125	0.35	9
1205-1xx	24-36	400	400	275	175	0.25	16
1205-2xx	36-48	350	350	250	150	0.30	21
1205-3xx	12	400	400	275	175	0.25	9

### DIMENSIONS

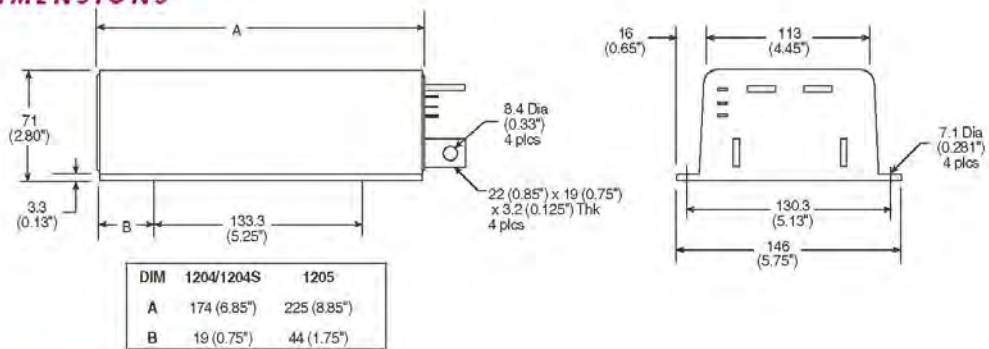

### TYPICAL WIRING DIAGRAM

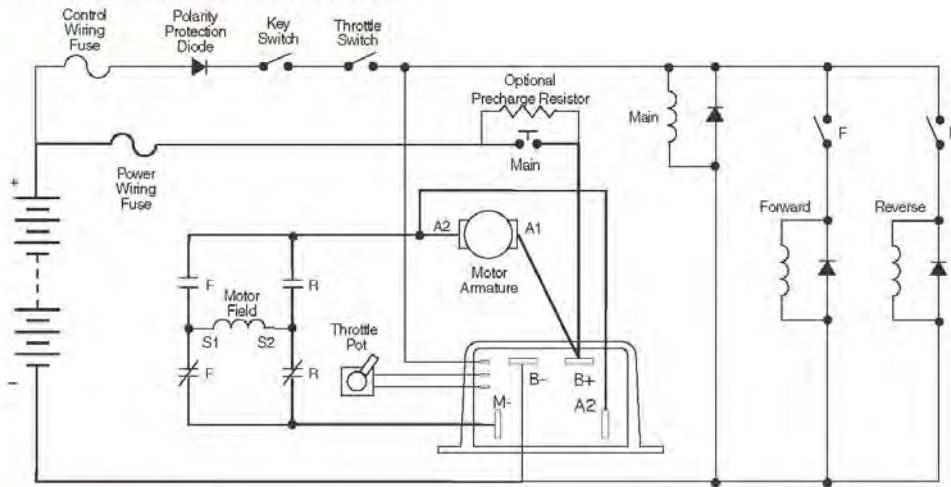

**WARRANTY** Two year limited warranty from time of delivery.



is a trademark of Curtis Instruments, Inc.

Specifications subject to change without notice

©2006 Curtis Instruments, Inc.

50036 REV C 8/06

## Chapter 11—Propulsion

It could be argued that understanding propeller design and choosing the right one is a black art. Two sheets in this section are included just to show the complexity of the subject. In World Championship racing, 2, 3, 4, and even 5 blade props have been used successfully.

It is first necessary to understand their dimensions. Props are described in two numbers: the outside diameter of the blades and the distance a prop will travel in one revolution. In the design of the system optimum motor RPM can be determined and now the prop must be matched. If the prop is too big, the motor will be overburdened and the prop will never get up to speed. In essence, it is in “too high of a gear”. If the prop is too small, or the pitch too flat, it will spin (cavitate) and will be very ineffective.

Another important physical feature of a prop is the hub. Props for outboard motors typically have large hubs to match up with the lower end of the drive system. When put on a relatively small drive shaft, the hub will cause unnecessary drag. Props for inboards typically have much smaller hubs.

The mounting of the prop on the drive shaft varies. Many outboards use a sheer pin. In this case, there is a hole through the shaft and perpendicular to it, just forward of the prop. A rod of soft metal goes through the hole and the hub of the prop slips over it. The end of the shaft is threaded and a washer, nut and cotter pin secure the prop. This is done so that when the prop hits bottom or a hard surface, the pin sheers, rather than breaking a prop blade. A sheer pin is not needed for the conditions of the Solar Cup. This is one of the easiest mounting styles.

On inboards, it is typical to have a keyway milled into the shaft and hub and a key is used to prevent slippage. The shaft is usually tapered to serve as a stop for the hub going forward. The end of the shaft is threaded and uses a nut and cotter pin. These work well but it can be a challenge to cut the taper on the shaft. Sources, such as Glen-L, sell shafts with the taper, but it must match the taper of the hub.

A third method is the use of a splined shaft. This is the most positive way of preventing slippage on the shaft but cutting splines is very difficult.

In recent years, two bladed props, which look like airplane props, have become more popular. One reason for this has been the field of relatively high-speed human powered boats. **Free Enterprises** makes props for this application. They are rather expensive but very well suited to the application.

Finally, it is not unusual to have a Sprint prop and an Endurance prop. There are many advantages. Remember, before you start buying any, the hubs of these two must be the same so they can be easily interchanged. Also, check the direction of rotation of your motor. **Be sure the direction of rotation of the motor and prop are the same!!**

## PROPELLERS

To understand how to analyze a propeller it is essential to understand its properties. There are 3 properties of a propeller that are significant to its application: pitch, diameter, and rake. A small change in diameter of a propeller will affect its performance greater than a small change in pitch. This means, if you wish to increase the overall speed of your boat, a change in diameter would be more effective than a change in pitch. However, this change in diameter would depend on the amount of horsepower available from your motor. If your engine is capable of reaching its maximum rpm's with the current propeller, it may be beneficial to increase the diameter of the propeller only by 1 or 2 inches. The pitch of a propeller is theoretically the number of inches the propeller will travel in one full revolution. Actually, the propeller's travel in one revolution varies due to slippage.

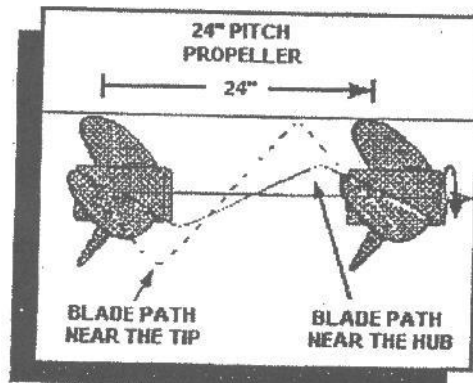

View of pitch

The rake of a propeller is the measurement of the tilt angle of the blade's tip toward or away from the gear case. The angle is measured on the line extending from the center of the hub through the center of one blade. The rake angle of a propeller is significant in regard to the boat hull spec and position.

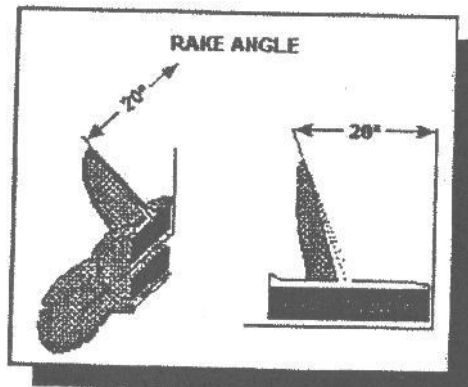

View of rake

Step 1 – find the speed of the water at the propeller using Propeller Chart A. The SANTA MARIA has her propeller in an aperture, so it is .85 of the boat’s speed. 6.7 x .85 = 5.7 knots. Find this value to the 2-½ power (for 5.7 knots, it is equal to 77), which we need for the next formula, which is:

$$\text{Shaft R.P.M.} \times \sqrt{\text{H. P. at Prop.}}$$

$$\text{BP} = \frac{\text{Shaft R.P.M.} \times \sqrt{\text{H. P. at Prop.}}}{\text{Speed of water at Prop. To the } 2 \frac{1}{2} \text{ power}}$$

$$2000 \times \sqrt{34.5}$$

$$\text{BP} = \frac{2000 \times \sqrt{34.5}}{77} = 153$$

### PROPELLER CHART A

KNOTS	VALUE OF SPEED OF WATER AT PROP. TO 2 ½ POWER									
	TENTHS OF KNOTS									
	.0	.1	.2	.3	.4	.5	.6	.7	.8	.9
5	56	59	62	65	68	71	74	77	81	84
6	88	92	96	100	104	108	112	116	120	125
7	130	134	139	144	149	154	159	164	170	175
8	181	167	192	198	204	211	217	223	230	236
9	243	250	257	264	271	278	286	293	301	388
10	316	324	332	340	349	357	366	374	383	392
11	401	410	420	429	439	448	458	468	478	488
12	495	509	520	530	541	552	563	575	586	598
13	609	621	633	645	657	670	682	695	707	720
14	733	746	760	773	787	801	814	828	843	857
15	871	886	901	916	931	946	961	977	992	1008
16	1024	1040	1056	1073	1089	1106	1123	1140	1157	1174
17	1191	1209	1227	1245	1263	1281	1299	1318	1337	1356
18	1375	1394	1413	1432	1452	1472	1492	1512	1532	1553
19	1574	1594	1615	1636	1658	1679	1701	1722	1744	1767
20	1789	1811	1834	1857	1880	1903	1926	1950	1973	1997
21	2021	2045	2069	2094	2118	2143	2168	2193	2219	2244
22	2270	2296	2322	2348	2375	2401	2428	2455	2482	2509
23	2537	2265	2592	2620	2649	2677	2706	2734	2763	2792
24	2822	2851	2881	2911	2941	2971	3001	3032	3063	3094
25	3125	3156	3188	3220	3251	3283	3316	3348	3381	3414
26	3447	3480	3514	3547	3581	3615	3649	3684	3718	3753
27	3788	3823	3859	3894	3930	3966	4002	4038	4075	4111
28	4148	4186	4223	4261	4298	4336	4374	4413	4451	4490
29	4529	4568	4607	4647	4687	4727	4767	4807	4848	4888
30	4929	4971	5012	5054	5095	5137	5180	5222	5265	5308

Speed of water at Prop. = .60 boat speed – small ships

.85 boat speed – boats with Prop in aperture

.90 boat speed – boats with Prop. In clear

Step 2 – Use Propeller Chart B, which has curves for three-bladed propellers. Enter with BP = 153 and spot it just above the Max. Efficiency Line. Then pick off Pitch Ratio = .57 at side of chart, Efficiency = .38 on line slanting up to the left; Delta = 435 on line slanting up to the right. Now we can calculate the diameter from this formula:

$$\text{Diam.} = \frac{\text{Speed of Water at Prop.} \times \text{Delta}}{\text{Shaft R.P.M.}}$$

$$\text{Diam.} = \frac{5.7 \times 435}{2000} = 1.24' \text{ (3 bladed)} = 14.9''$$

For two-bladed Props. Add 5%.  $114.9 \times 1.05 = 120.6''$

And we can calculate the pitch as follows:

Pitch = Pitch Ratio X 3 Blade Diam.

$$.57 \times 14.9'' = 8.5''$$

So the two bladed propeller to use will be 16'' Diam. X 9'' Pitch

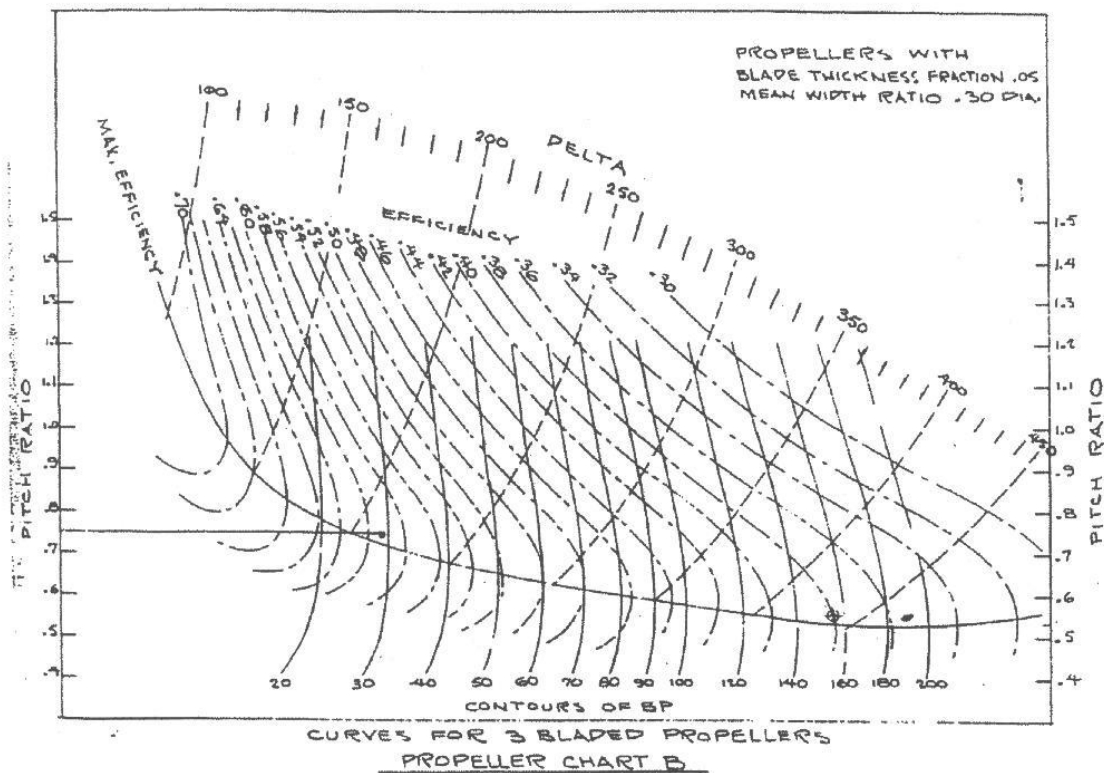

Curves for 3 bladed propellers  
Propeller Chart B

The sprint propeller (left) and the two choices that will be considered for use as our endurance propeller (two right).

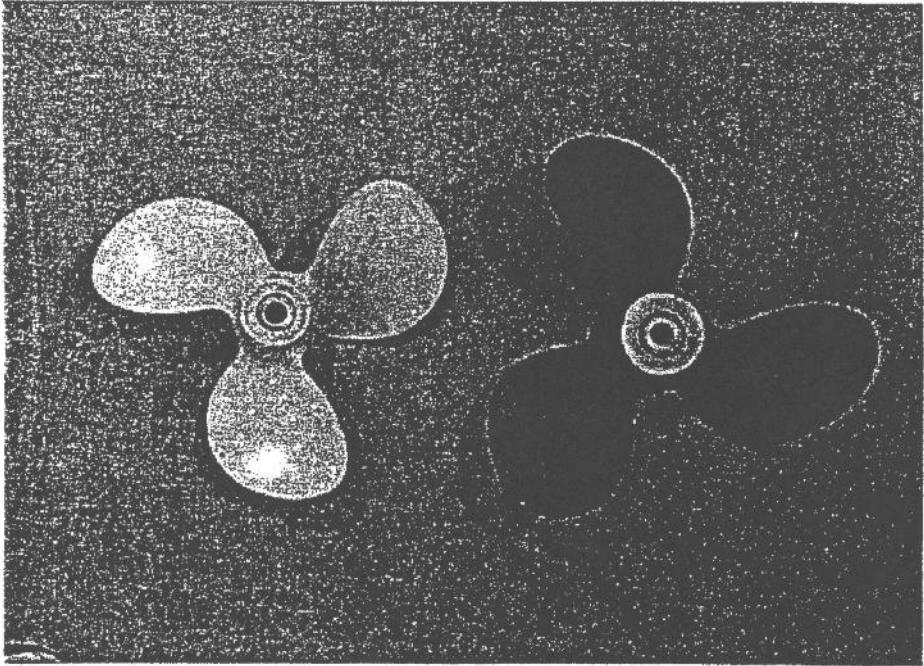
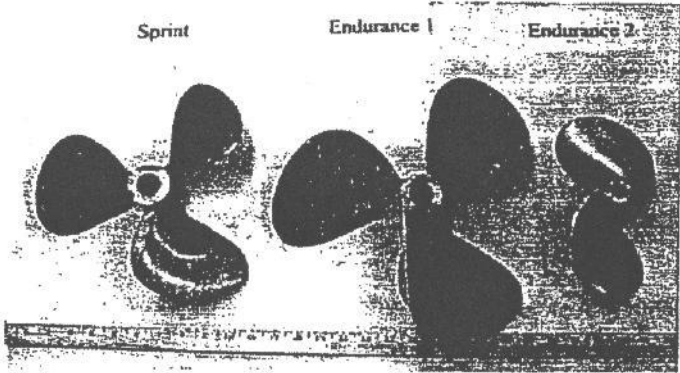

Ogival (3 Bladed) Propellers Used in Sprint and Endurance Races

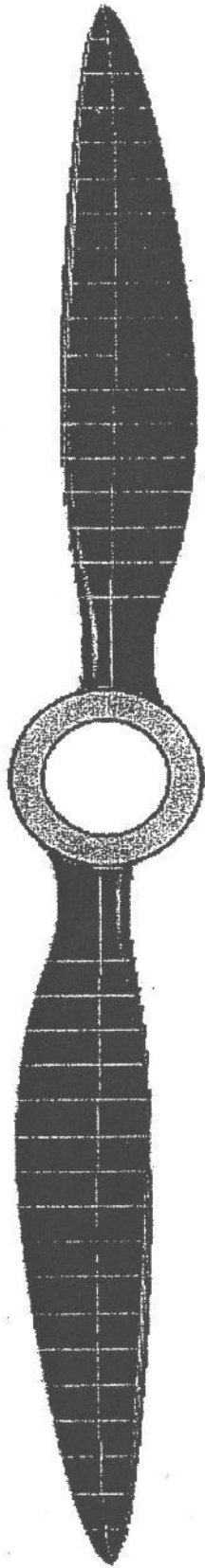

## Chapter 12—Drive Train

If there is a clear starting point in designing a solar boat for this competition, it is with the Drive Train. For the purpose of this discussion, the drive train will be considered to be the **entire mechanical connection from the motor to the propeller.**

Motor selection is discussed elsewhere in this workbook. As various motors are considered, it is important to look at the optimum RPM at 24 VDC. From the Propeller section, it is possible to estimate the desired RPM of the prop. Often, these do not match. As a rule of thumb, the motor will have an RPM about 2.5 to 3 times that of the prop. The purpose of the drive train is to transfer the power, generated by the motor to the propeller, at the desired RPM.

### POSITION AND DESIGN

Certainly, an electric trolling motor could be used to drive the boat. It works, but speeds are simply too low to be competitive. One approach, which has been occasionally used, is to find an old outboard motor, remove the internal combustion engine, and replace it with an electric motor. Performance for this type of system has been rather marginal. It creates some weight distribution problems, raises the center of gravity and seems to have significant internal power losses.

A few external horizontal drives have been tried and in principle, can be quite successful, but they are very mechanically complex and often difficult to work on,.

As a result, the most common approach is the traditional “inboard” where the motor(s) are well forward of the transom and a drive shaft exits the hull at an angle of approximately 12 – 15 degrees.

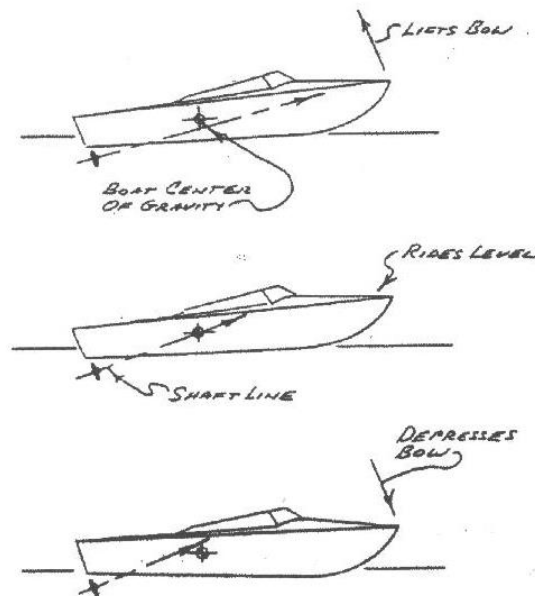

From this figure, it can be seen that the angle of the drive shaft is very important. Unfortunately, since the canoe hull was designed for paddling, not for a power system. In 2001-2002, over a dozen high schools were quite successful with a variety of configurations. As a starting point, take time to study how the boat rides in the water with a skipper on-board. Because the bottom of the boat is not flat from bow to stern, it is very important to estimate the position of the aft portion –when the boat is in the endurance and especially the Sprint configuration. By adding weight in the aft portion, a second person or sandbags, it is possible to get a pretty good idea of the appropriate longitudinal center of gravity. (cg)

Once a desirable position is determined, place an “angle-o-meter” on the floor of the boat in the area just aft of the bulkhead, where the motor(s) will be mounted. Once the boat is back on a solid ground, position the boat on a solid surface and reproduce this angle. Viewing the hull from the side, use a long straight edge to represent the shaft and adjust the position until a desired position is found. Using a protractor, or the angle-o-meter, measure the angle between the shaft and the bottom of the boat where the “strut” will be located. This will be the angle you need for the strut. It will not be the same angle for the motor mount because the bottom of the boat curves from front to back. The motor mount angle is likely to be about 2-3 degrees smaller than the strut angle. If you buy a stuffing box or “log”, the angle of it will be slightly less than the strut angle.

One easy way of adjusting these components into the correct alignment is to get everything into the right position with the boat upside-down, drill mounting holes, and connect all components. It will now be possible to inset spacers or wedges to come very close to the correct alignment. By making up a paste of epoxy and filler, bond the spacers and sedges into position and double check alignment. When the epoxy hardens, everything should be in the right place. It should now be relatively easy with the hull right side up to determine the design and angle of the motor mount.

## **SUPPORTING THE DRIVESHAFT**

It is vital that the alignment of the shaft stays fixed. Turning at hundreds of RPM, forces are very large. The most obvious force is the rotational one, caused by the motor. What is sometimes overlooked is the thrust, created by the prop. There are essentially two way to handle these forces. First, is what we will call the “pillow block” approach. In this design, two pillow blocks are mounted internally; there is no external support of the drive shaft. The second approach, common to most inboards uses an external bearing, mounted in a “strut”. In either case, the forward bearing must carry both the radial load and the thrust load.

## **DRIVE SHAFT SIZE**

In selecting the size for the shaft, a number of factors might be considered. (Quite a bit of material is in the back of this section, which may prove to be helpful).

Strength – There are several features of a solid shaft that are desirable. It can be machined as necessary from one piece of material. Its high strength to diameter ratio means that the

diameter can be kept rather small, thus reducing the external drag caused by it and its support. One drawback is weight.

The alternative is a tube, as used in rear wheel drive cars. Here, a large diameter tube gives very good strength but requires at least one fitting for the mounting of the prop. Some of the weight that is saved with the lighter tube may be lost to heavier bearings, due to the increased diameter. The larger diameter will also cause more drag as it goes through the water.

Length – It is not unusual to have a rather long shaft, to keep the shaft angle small. In principle, the smaller the angle, the more thrust is directed forward. In other hulls, a long shaft may help move the cg forward. With the ability to significantly adjust the cg in the hull being used for Solar Cup, this is not important. Longer length can also lead to extra weight and problems with wobble in the shaft.

Material – There is no doubt that synthetic material can be used for the shaft and, therefore, achieves significant weight reductions; but this is not easy to do. Some form of steel is most commonly used, since the boat is not being operated in salt water. (If it were, a brass shaft is almost always used.)

Commonality – Although a particular diameter might seem best, it is important to remember that it must be compatible with many other components such as pulleys, bearings and props. Usually, either  $\frac{3}{4}$ " or 1" is used.

## **TRANSMISSION**

Depending on configuration decisions for the Endurance and Sprint events, one may need a fixed ratio transmission or a variable ratio transmission. If the design of the system only requires a fixed reduction, there are gearboxes available, which are sturdy and can be ordered in many ratios and shaft sizes.

In most applications, the optimum RPM needs to be changed and thus a variable ratio system is needed. This means one or more pulleys or sprockets on the drive shaft and one or more on the motor(s). Two connections systems are most commonly used. Traditionally, roller chain is used because friction is low and the length is rather easily adjusted. In recent years, there have been huge improvements in cogged belts such that their efficiency is as good as chain. The one drawback is that the belts come in fixed lengths and thus the relative position of the motor and shaft becomes very important.

Sprockets come in all sizes to that in the course of testing; it is not difficult to try more than one ratio. Belt pulleys are also available in many sizes but changing them maybe more costly and time consuming.

One final note of caution. If you have not worked with chain, you may not be aware that it “stretches”. Do not undersize the chain or belt and be sure to have a tensioning system

## ALIGNMENT OR COUPLING

Although a rigid sleeve type of coupler can join some components, it is often desirable to use a flexible coupler. A common one is shown in the following pages. It uses a rubber “link” between fittings that go on the ends of the shafts to be joined. This is only used when alignment is good. The alternative is to use a “U” joint CV joint but there are reliability issues as the angle between the two shafts increases. In any case, setscrews are often used to fix a coupling on to a shaft. **The failure of this attachment has traditionally been a real problem.** If possible, use a pin or bolt through the fitting and shaft. Even then, be certain the bolt has sufficient strength.

## MOUNTING

The floor of the boat is only ¼” plywood so it may not be suitable for the direct mounting of components. Generally, some type of platform must be made, commonly out of aluminum, for the mounting of the motor, transmission, and forward bearing. One great advantage of doing this is for ease of testing. One possibility is that if the platform is a true module, it can be tested either in or out of the boat. Large flat sheets of material should be avoided, as they will flex. Structures using angle or box section material are usually lighter and much more rigid.

Once the platform is designed, the hull can be reinforced, if needed, and suitable fasteners mounted in it in order to secure the platform.

## STUFFING BOX

At some point in the drive train, it is necessary for the shaft to go through the hull. A stuffing box is used to seal the area around the shaft and thus prevent water from leaking into the hull. These boxes are available from various sources. One is Glen-L. Quite a bit of reference material is included in the back of this section.

## STRUT

If the drive shaft is supported externally at the aft end, it is done with a bearing in a strut. These struts are available from various sources. Again, one is Glen-L. Quite a bit of reference material is included in the back of this section.

## SUMMARY

Many subsystems of the boat cannot be designed until the drive train design is determined. These include the rudder, probably the steering, room for the batteries and their mounting, and the bilge pump, just to name a few.

It is suggested that simple cardboard mockups, perhaps using a wood dowel or a piece of PVC for the shaft, may be an excellent starting point. Once the concept is agreed upon, it is most likely that it will be necessary to go to a machine shop to have some fabrication done.

Consider taking the hull and other parts of the drive train so the fabricator sees the whole picture not just one part.

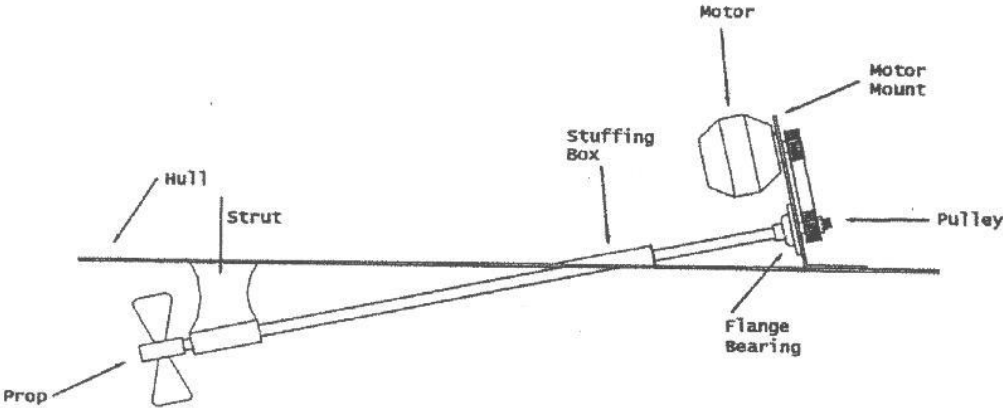
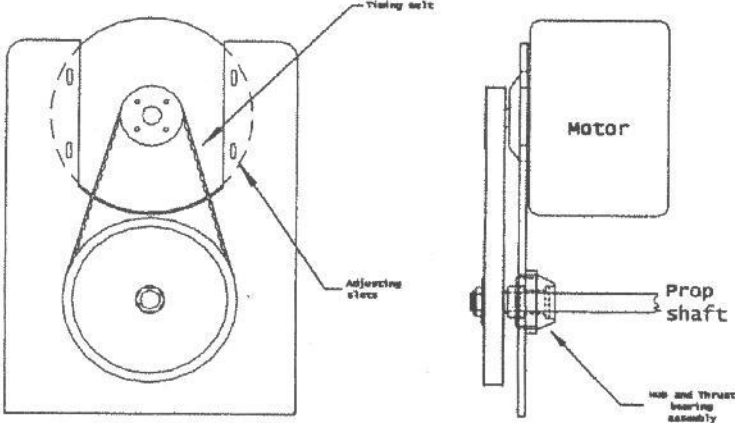

### Power Conversions

$$(50 \text{ amp/hr})(24 \text{ V})(3600\text{s/hr}) = (4320000\text{J})/(7200\text{s}) = 800 \text{ W} * 85\%_{\text{eff}} = 510\text{W total}$$

### **Torque from Motor**

$$T = (6300 * \text{Hp})/(\text{rpm})$$

$$T = (6300 * 12)/(1500\text{rpm}) = 504 \text{ lb-in}$$

### **Shaft Sizing**

#### 1/2" solid shaft

$$J = (\pi/32)(D)^4$$

$$J = (\pi/32)(1/2 \text{ in})^4 = 0.006136 \text{ in}^4$$

$$\tau = Tr/J$$

$$\tau = (504 \text{ lb-in})(1/4 \text{ in})/(0.006136 \text{ in}^4) = 20534 \text{ psi}$$

$$\tau_{\text{allow}} > 20534 \text{ psi}$$

-assume a safety factor of 1.5

$$\tau_{\gamma} > 20534 \text{ psi} * 1.5 = 30801 \text{ psi}$$

$$\tau_{\gamma}/2 = 30801 \text{ psi}$$

$$\tau_{\gamma} = 61603 \text{ psi} < 67000 \text{ psi}$$

#### 3/4" \* 9.12" wall shaft

$$J = (\pi/32)*(D_o^4 - D_i^4)$$

$$J = (\pi/32)*(0.75^4 - .51^4) = 0.024421 \text{ in}^4$$

$$\tau = Tr/J \text{ (not sure about the backlash symbol?)}$$

$$\tau = (504 \text{ lb-in})*(0.375 \text{ in})/(0.024421 \text{ in}^4) = 7739 \text{ psi}$$

$$\tau_{\text{allow}} > 7739 \text{ psi}$$

$$\tau_{\gamma} > 7739 \text{ psi} * 1.5 = 11608.9 \text{ psi}$$

$$\tau_{\gamma}/2 = 11608.9 \text{ psi}$$

$$\tau_{\gamma} = 23218 \text{ psi} < 67000 \text{ psi}$$

#### Approximate Shaft Weight $W = \rho(8/4)(D_o)^2 - (D_i)^2(L)$

$$W = (0.3 \text{ lb/in}^3)(8)(9.375''^2 - (0.225''^2)(60 \text{ in}) = 4.28 \text{ lb}$$

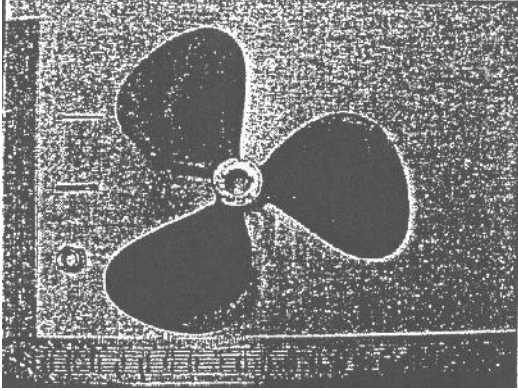

Sprint Propeller

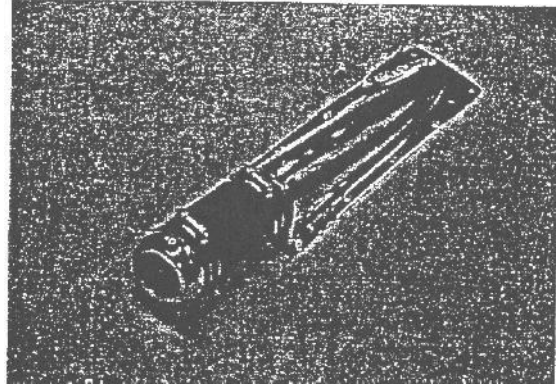

Shaft Log Assembly

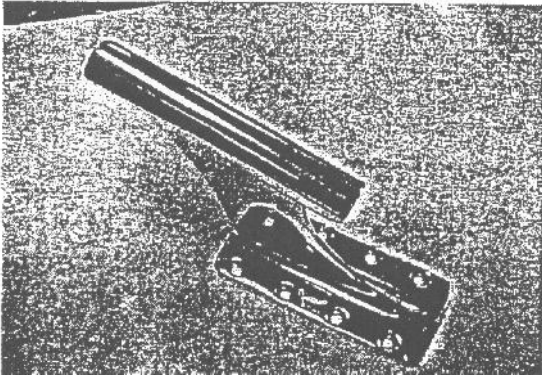

Strut

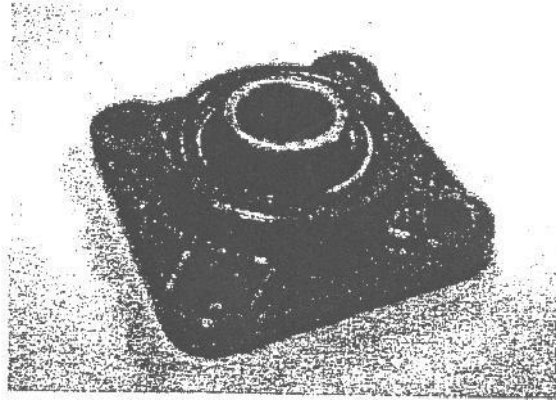

Thrust Bearing

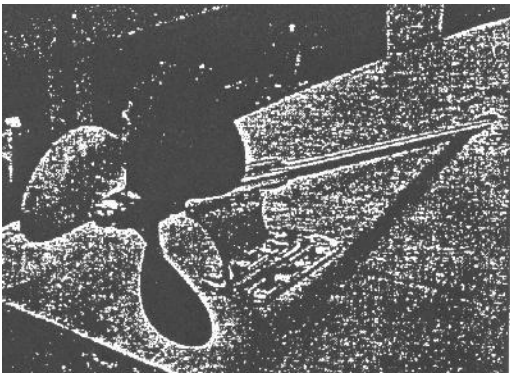

Inboard Assembly (Bottom Side)

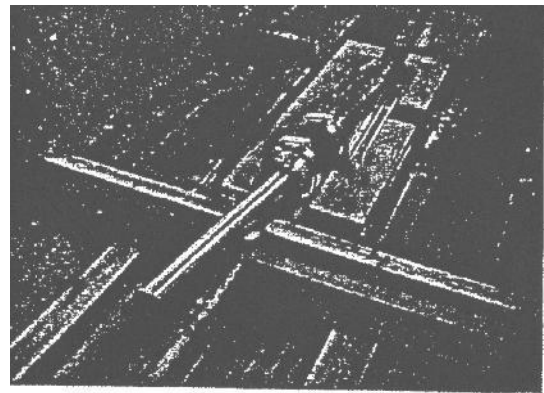

Inboard Assembly (Top Side)

## TYPICAL SHAFT LOGS

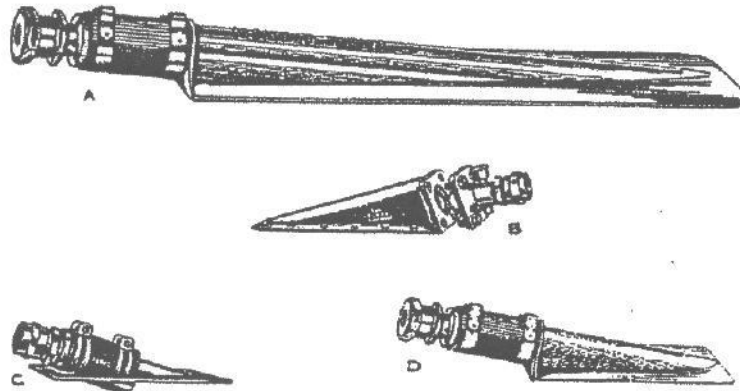

- A—SELF ALIGNING TYPE FOR LOW ANGLE INSTALLATION  
 B—UNIVERSAL BALL JOINT TYPE  
 C—SELF ALIGNING TYPE FOR SHORT COUPLING  
 D—SELF ALIGNING TYPE FOR STEEP ANGLE INSTALLATION

Typical shaft log assemblies

ANGLE IN DEGREES	DROP LENGTH
8°	.1405
9°	.1495
9½°	.1584
10°	.1673
10½°	.1763
11°	.1853
11½°	.1944
12°	.2035
12½°	.2126
13°	.2217
13½°	.2309
14°	.2401
14½°	.2493
15°	.2586
15½°	.2679
16°	.2773
16½°	.2867
17°	.2962
17½°	.3057
18°	.3153
18½°	.3249

### DETERMINING SHAFT ANGLES FOR INBOARD INSTALLATIONS

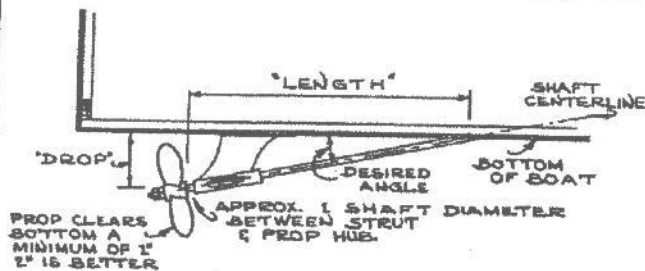

TO DETERMINE THE ANGLE OF A PROPELLOR SHAFT WITH THE BOTTOM OF THE BOAT—FIRST MEASURE THE "LENGTH" IN INCHES FROM THE POINT THE CENTERLINE OF THE SHAFT IS TO GO THROUGH THE BOTTOM OF THE BOAT TO THE BACK SIDE OF THE PROP HUB IN A LINE PARALLEL TO THE KEEL—THEN MEASURE THE "DROP" IN INCHES FROM THE BOTTOM OF THE BOAT—NEXT—DIVIDE THE "DROP" BY THE "LENGTH"—THE SHAFT ANGLE MAY THEN BE NOTED ON THE CHART TO THE NEAREST ½—AS A FORMULA I—

$$\text{ANGLE (PER CHART)} = \frac{\text{DROP}}{\text{LENGTH}}$$

Plate 37 – a method to determine the shaft angle for a straight shaft installation. Propeller clearance calculation for inboard installations.

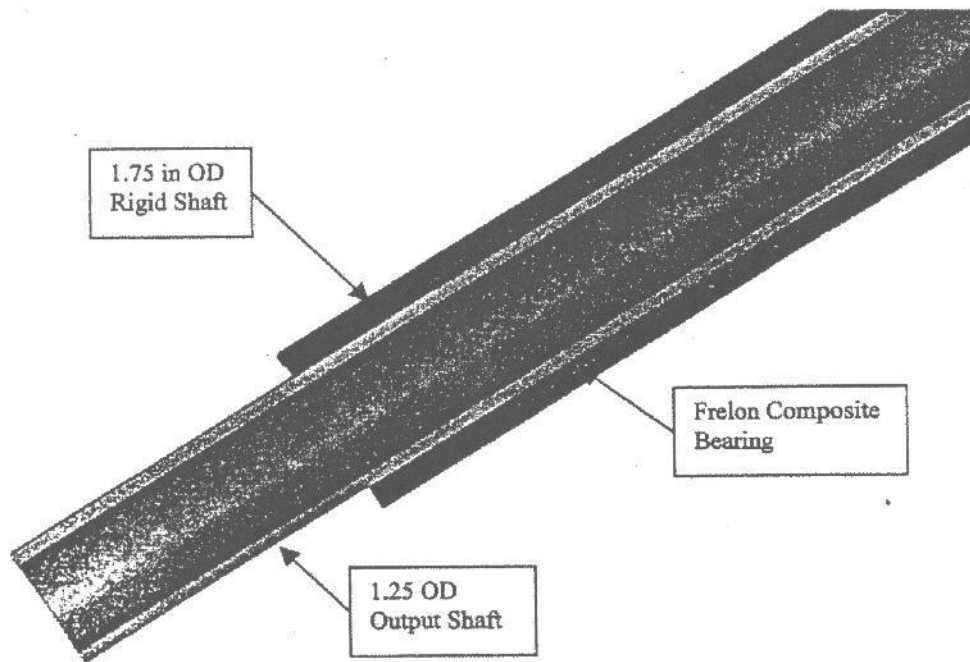

1.75 in OD  
Rigid Shaft

Frelon Composite  
Bearing

1.25 OD  
Output Shaft

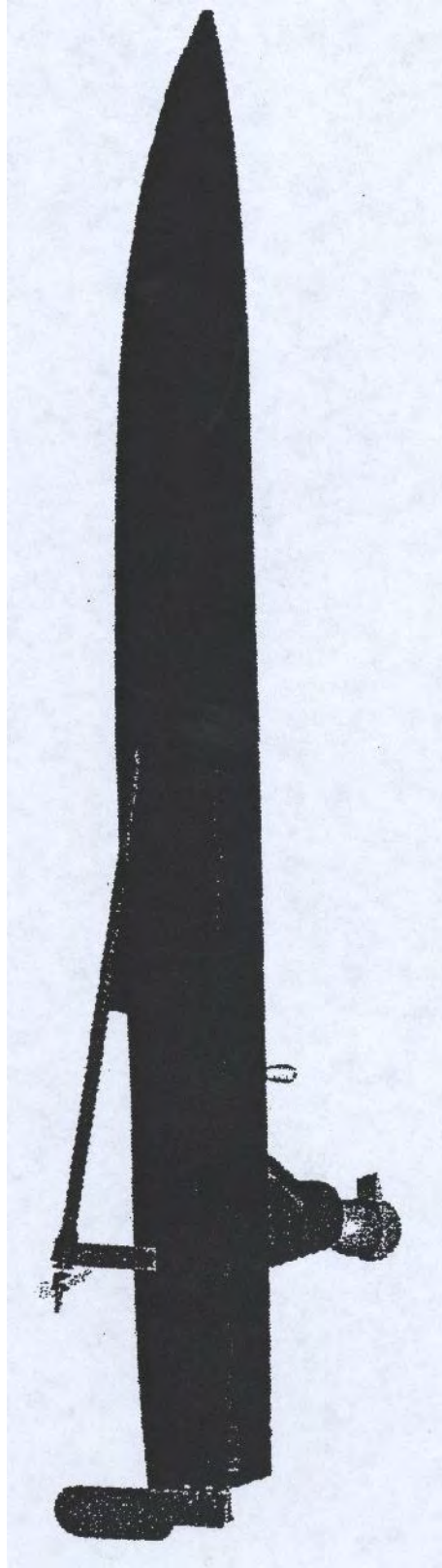

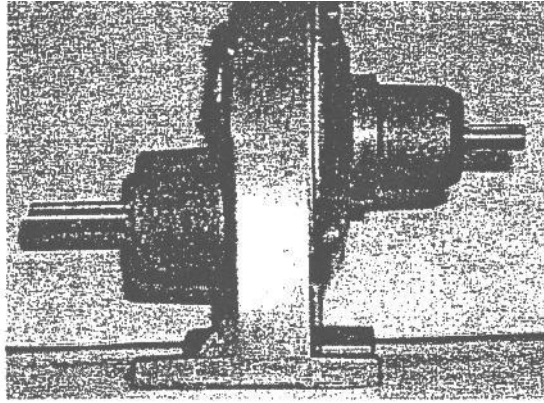

Reduction Gear

## Setscrew Sizing

### Assumptions:

Use of cup point socket setscrew  
steel setscrew on steel shaft  
Class 3A coarse or fine threads  
Class 2B holes.

### Schematic:

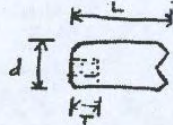

### Rules of Thumb:

Setscrew should have length about  $\frac{1}{2}$  shaft diameter  
Holding Power applies to both thrust resistance  
and torsion resistance

### Selection:

Size =  $\frac{3}{8}$ "  
Setting Torque = 290 in·lb  
Holding Power = 2000 lb  
Factor of Safety = 1.5  $\rightarrow$  2.0

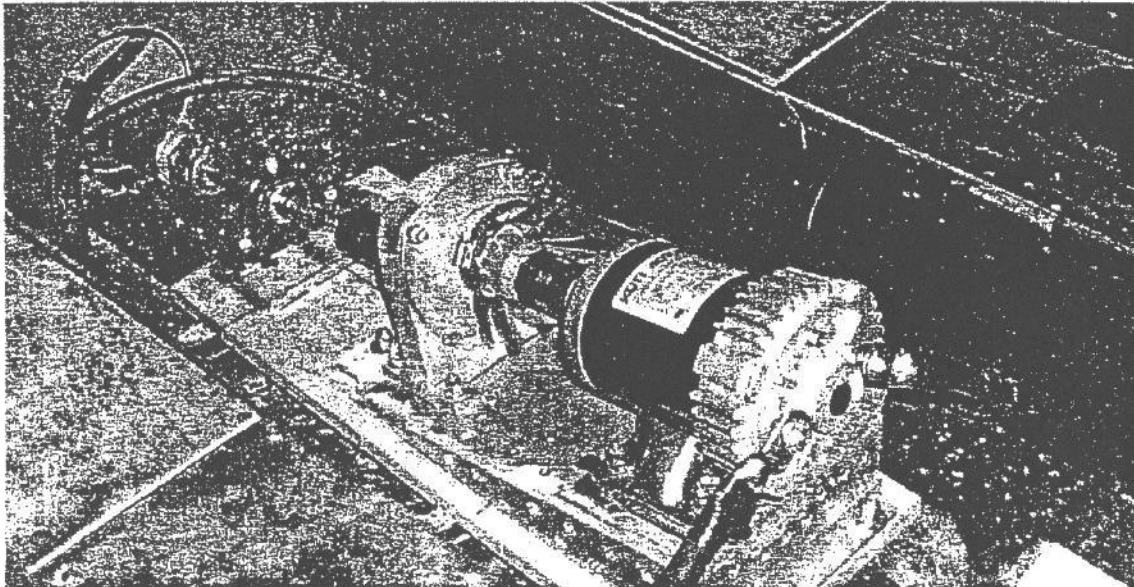

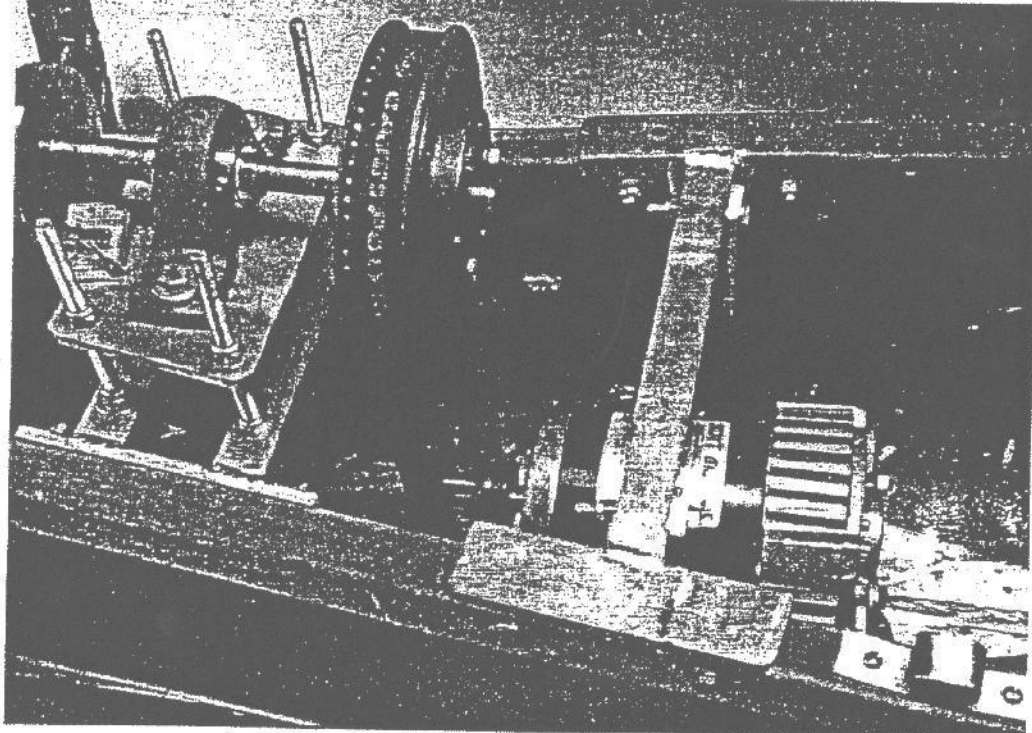

Sprint Motor configuration with the jack shaft support

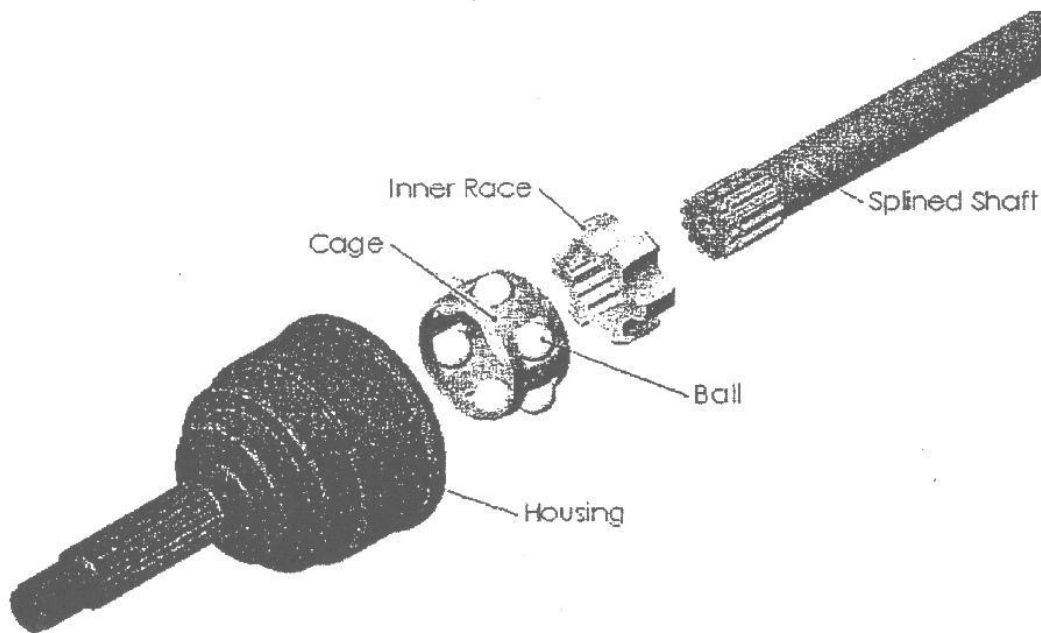

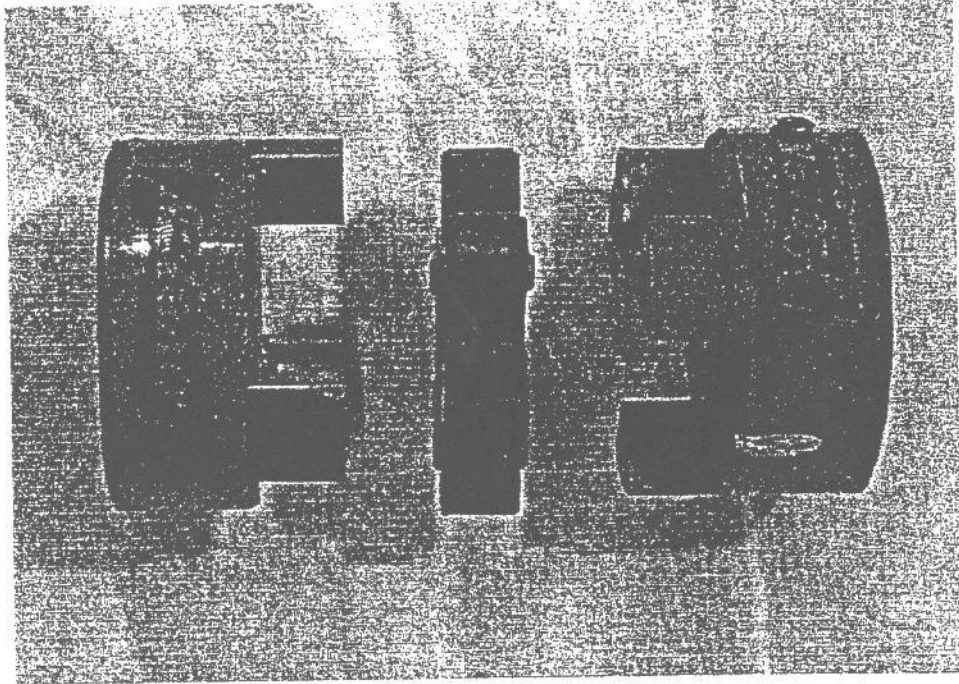

Lovejoy Shaft Connectors



**\*II Steel - Single QD Bushed Sprockets**  
 .35 - 3/8" Pitch - Single



QD Bushed



**All Steel - No. 35 - 3/8" Pitch - Double - Type B - Plain Stock Bore**  
 Plain Stock Bore Sprocket.

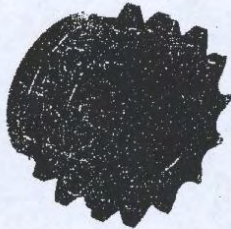

**No. 35 - 3/8" Pitch - Single - Type B - Plain Stock Bore**



**MORSE**  
 Chain Breakers



For pin removal. Reduced time required for disconnecting roller chains. Constructed of finished steel. Moving parts hardened to increase strength and wear-resistance.

Order No.	No.	Wt. (lb)	Roller Chain Size	Pitch	Net Price ea.
MA4801957	311006	.61	25-60	3/8-3/4	\$ 18.76
MA4801973	311007	1.50	60-100	3/4-1 1/4	79.87
MA4803904	311502	8.30	120-160	1 1/2-2	161.04

**Roller Chain Pullers**  
 Used for installation of roller chains.



Order No.	No.	Wt. (lb)	Roller Chain Size	Jaw Spread	Net Price ea.
MA4800554	333174	.31	35-60	2 in	\$ 26.06
MA4803904	311502	8.30	120-160	1 1/2-2	161.04

Continued from previous page

Offset Link

Order No.	No.	Wt. (lb)	Tensile Shear Strgth.	Pitch	Box Quantity FL/Ea.	Net Price ea.
MA4800025	25 O/L	1.00	875 lb-f	1/4 in	10	\$ 3.47
MA4800082	35 O/L	.40	2,100 lb-f	3/8 in	25	2.89
MA4800199	40 O/L	.80	3,700 lb-f	1/2 in	25	3.33
MA4800405	41 O/L	.80	2,000 lb-f	1/2 in	25	2.77
MA4800546	50 O/L	.89	6,100 lb-f	5/8 in	25	4.25
MA4800744	60 O/L	2.00	8,500 lb-f	3/4 in	25	5.42
MA4800884	80 O/L	17.10	14,500 lb-f	1 in	20	8.51
MA4801056	100 O/L	1.80	24,000 lb-f	1 1/4 in	5	15.32
MA4801189	120 O/L	2.90	34,000 lb-f	1 1/2 in	5	30.69
MA4801282	140 O/L	1.90	46,000 lb-f	1 3/4 in	2	30.03
MA4801338	160 O/L	2.70	58,000 lb-f	2 in	2	46.13

Roller Link

Order No.	No.	Wt. (lb)	Tensile Shear Strgth.	Pitch	Box Quantity FL/Ea.	Net Price ea.
MA4800041	25 R/L	.50	875 lb-f	1/4 in	10	\$ 0.77
MA4800090	35 R/L	2.10	2,100 lb-f	3/8 in	25	0.88
MA4800207	40 R/L	4.20	3,700 lb-f	1/2 in	25	1.11
MA4800413	41 R/L	2.50	2,000 lb-f	1/2 in	25	0.88
MA4800553	50 R/L	6.90	6,100 lb-f	5/8 in	25	1.38
MA4800751	60 R/L	10.00	8,500 lb-f	3/4 in	25	2.09
MA4800882	80 R/L	17.10	14,500 lb-f	1 in	20	3.44
MA4801064	100 R/L	25.80	24,000 lb-f	1 1/4 in	5	6.33
MA4801187	120 R/L	38.70	34,000 lb-f	1 1/2 in	5	10.82
MA4801270	140 R/L	49.50	46,000 lb-f	1 3/4 in	2	18.63
MA4801346	160 R/L	66.10	58,000 lb-f	2 in	2	21.84

Rex Roller Chain

Roller Chain  
ANSI Standard - Single Strand



Attachments available. May be used interchangeably with manufacturers who conform to ANSI standards.  
Compliances. Conform to ANSI Requirements.

Riveted

Order No.	No.	Wt. (lb)	Pitch	Work Load Limit	Box Quantity FL/Ea.	Net Price ft.
MA6020002	25 RV	.08	1/4 in	940 lb	10	\$ 7.64
MA6020010	35 RV	.22	3/8 in	2,100 lb	10	2.44
MA6020036	40 RV	.39	1/2 in	3,700 lb	10	2.82
MA6020028	41 RV	.27	1/2 in	2,000 lb	10	2.30
MA6020044	50 RV	.70	5/8 in	6,100 lb	10	3.80
MA6020061	60 RV	1.02	3/4 in	8,500 lb	10	4.53
MA6020069	80 RV	1.87	1 in	14,500 lb	10	8.08
MA6020077	100 RV	2.72	1 1/4 in	24,000 lb	10	15.84
MA6020085	120 RV	3.72	1 1/2 in	34,000 lb	10	23.36
MA6020093	140 RV	4.69	1 3/4 in	46,000 lb	10	28.55
MA6020101	160 RV	6.12	2 in	58,000 lb	10	33.89

Riveted, 50 FL Length

Order No.	No.	Wt. (lb)	Pitch	Work Load Limit	Box Quantity FL/Ea.	Net Price ft.
MA6020559	35 RV50FT	.22	3/8 in	2,100 lb	50	\$2.27
MA6045546	40 RV50FT	.39	1/2 in	3,700 lb	50	2.71
MA6045553	50 RV50FT	.70	5/8 in	6,100 lb	50	3.34
MA6041123	60 RV50FT	1.02	3/4 in	8,500 lb	50	4.21
MA6040654	80 RV50FT	1.87	1 in	14,500 lb	50	8.27

Available only in riveted construction. All other sizes may be furnished cottered or riveted.

Riveted, 100 Ft. Length

Order No.	No.	Wt. (lb)	Pitch	Work Load Limit	Box Quantity FL/Ea.	Net Price ft.
MA6020560	35 RV100FT	.22	3/8 in	2,100 lb	100	\$2.27
MA6046603	40 RV100FT	.39	1/2 in	3,700 lb	100	2.71
MA6045421	41 RV100FT	.27	1/2 in	2,000 lb	100	2.13
MA6020053	50 RV100FT	.70	5/8 in	6,100 lb	100	3.34
MA6042889	60 RV100FT	1.02	3/4 in	8,500 lb	100	4.21
MA6020072	80 RV100FT	1.87	1 in	14,900 lb	100	8.27

Cottered

Order No.	No.	Wt. (lb)	Pitch	Work Load Limit	Box Quantity FL/Ea.	Net Price ft.
MA6020143	60 COTT	1.02	3/4 in	8,500 lb	10	\$ 8.46
MA6020160	80 COTT	1.67	1 in	14,500 lb	10	11.35
MA6020168	100 COTT	2.72	1 1/4 in	24,000 lb	10	17.19
MA6020176	120 COTT	3.72	1 1/2 in	34,000 lb	10	28.26
MA6020184	140 COTT	4.69	1 3/4 in	46,000 lb	10	30.30
MA6020182	160 COTT	6.12	2 in	58,000 lb	10	35.57

Connecting Link, Spring Clip

Order No.	No.	Wt. (lb)	Pitch	Work Load Limit	Box Quantity FL/Ea.	Net Price ea.
MA6020234	25 CONN LK SC	.08	1/4 in	940 lb	25	\$3.51
MA6020625	35 CONN LK SC	.22	3/8 in	2,100 lb	25	0.26
MA6020641	40 CONN LK SC	.39	1/2 in	3,700 lb	25	0.19
MA6020275	50 CONN LK SC	.70	5/8 in	6,100 lb	25	1.42
MA6020283	60 CONN LK SC	1.02	3/4 in	8,500 lb	25	2.04
MA6043020	80 CONN LK SC	1.67	1 in	14,500 lb	10	3.43

Connecting Link Cottered

Order No.	No.	Wt. (lb)	Pitch	Work Load Limit	Box Quantity FL/Ea.	Net Price ea.
MA6020242	35 CONN LK	.22	3/8 in	2,100 lb	25	\$ 1.77
MA6020267	40 CONN LK	.39	1/2 in	3,700 lb	25	1.29
MA6020259	41 CONN LK	.27	1/2 in	2,000 lb	25	1.54
MA6020017	50 CONN LK	.70	5/8 in	6,100 lb	25	3.78
MA6042691	60 CONN LK	1.02	3/4 in	8,500 lb	25	2.46
MA6020291	80 CONN LK	1.67	1 in	14,500 lb	10	3.43
MA6020309	100 CONN LK	2.72	1 1/4 in	24,000 lb	10	5.09
MA6020317	120 CONN LK	3.72	1 1/2 in	34,000 lb	10	7.67
MA6020325	140 CONN LK	4.69	1 3/4 in	46,000 lb	10	10.68
MA6020333	160 CONN LK	6.12	2 in	58,000 lb	5	14.30

Offset Link

Order No.	No.	Wt. (lb)	Pitch	Work Load Limit	Box Quantity FL/Ea.	Net Price ea.
MA6027395	25 OFFSET LK	.08	1/4 in	940 lb	25	\$11.72
MA6020523	35 OFFSET LK	.22	3/8 in	2,100 lb	25	8.02
MA6020549	40 OFFSET LK	.39	1/2 in	3,700 lb	25	3.66
MA6029531	41 OFFSET LK	.27	1/2 in	2,000 lb	25	5.02
MA6029566	50 OFFSET LK	.70	5/8 in	6,100 lb	25	3.51
MA6020964	60 OFFSET LK	1.02	3/4 in	8,500 lb	25	4.40
MA6029572	80 OFFSET LK	1.67	1 in	14,500 lb	10	10.09
MA6029580	100 OFFSET LK	2.72	1 1/4 in	24,000 lb	10	15.36
MA6020988	120 OFFSET LK	3.72	1 1/2 in	34,000 lb	10	19.31
MA6029606	140 OFFSET LK	4.69	1 3/4 in	46,000 lb	10	22.77
MA6020914	160 OFFSET LK	6.12	2 in	58,000 lb	5	28.56

Continued on next page



See location directory at the back of the catalog for a listing of Applied Industrial Technologies' Service Centers or Call 1-877-279-2799.

## Chapter 13—Steering

Throughout the history of the Solar Splash, the one area of design that has caused the greatest problems on-the-water is the steering system. Perhaps one of the reasons is that it seems so simple. This discussion divides the topic into two components the rudder and the system used to move or control it.

Although it is possible to have unusual steering systems, the traditional rudder position in the area of the stem and on the centerline of the craft is the only case that will be discussed. Other configurations are possible but fraught with problems. For simplicity and reliability, this configuration is strongly recommended.

### THE RUDDER

The farther one looks into the shape of rudders, it becomes obvious that there are many designs. Two examples of computer generated rudder designs are shown. Both are relatively square, as compared with the very high aspect ratio rudders used on racing sailboats. High aspect means long and thin.

Before selecting a design, there are really two key factors to consider, 1) strength and 2) what are the turning demands? Going back centuries, the traditional rudder depends on the stern stem or transom for its hinge points. This system is commonly known as a “pintle and gudgeon” (P&G). In this system, the gudgeon is a fitting that mounts on the aft of the boat and provides a hole, which forms a pivot with the pintle or pin that is mounted on the rudder. Two sets are generally spaced as high and low as possible on the transom or stem for strength. To remove the rudder, just lift up and the pintles come right out of the gudgeons.

The next mounting option is to have a vertical shaft go through the stem section of the boat. This shaft is rigidly mounted and serves as a standpipe. The bottom of the outer shaft does not have to be sealed against the rudder shaft because the top is well above the waterline. This is a very positive way of mounting the rudder but removing it is somewhat difficult. By planning for the rudder when designing the drive shaft and position of the propeller, there should not be a problem with interference. This concept can be applied in two manners. First, the stern stem can be used to support the outer tube. Carefully drill a vertical hole through the stern stem. The outer tube can be secured in place with epoxy or other adhesive. The second method is to drill a hole in the floor of the boat, just forward of the stem. This is easier but then requires metal bracketry to support the top end.

The third method is sometimes known as a cantilevered rudder. In this design, the rudder is only supported at the top and depends on very strong and well-engineered fittings and materials. This method is not commonly used and is strongly discouraged.

The demands placed on the rudder are relatively small but the forces should not be underestimated. For the Endurance, speeds are relatively low and thus the forces are

small, but, for the maneuverability course, it is necessary to negotiate a complex course with tight turns. For the Sprint, the only demand is to keep the boat in a straight line, but speeds are much higher and therefore, the forces are much greater. These forces can be calculated, but it is necessary to know the boat speed, which will not be known until long after the rudder design decision must be made. Be sure to leave yourself some flexibility so that the blade of the rudder can be changed after testing.

If the P&G system is used and the mountings are reasonably far apart, the forces on the rudder will be minimized. If the rudder “blade” is made of a homogeneous material, it can be trimmed down in size during testing.

It is not uncommon to make the cross-section of the rudder a very streamlined shape but this can be very time consuming and very difficult to modify. All of these factors should be taken into consideration when making the design decision.

Finally, without a keel, there is nothing to give the boat directional stability and assist in turning. A keel adds drag, which is NOT desirable. An excellent alternative is a forward skeg. A fin from a surfboard is very suitable. By mounting one on the centerline, about 1/3 of the way back from the bow, the skeg gives the boat directional stability with minimum drag. At the same time, it serves as a pivot for the rudder greatly improving steering and reducing the requirements for the rudder size.

## CONTROLS

We will refer to the system that controls the position of the rudder as the “steering”, for lack of a better term.

The most basic steering system is a tiller, the handle on a coaster wagon. Move it, and the front wheels move. Let go, and who knows what will happen. This system is simple but requires one hand on the tiller at all times.

The system we are most familiar with is a “steering wheel”. No matter what the mechanical linkage in a boat application, move the wheel to a new position and it will stay there until moved again. This system is easy to use but relatively heavy and requires quite a bit of mounting and hardware.

There are many hybrid systems that in essence combine the simplicity of the tiller and the hands-off feature of the “wheel”.

Whatever system is employed, there are two elements that should definitely be adjustable. The first is the attachment, point on the steering arm that is on the top of the rudder. If the attachment point is too close in, there is a large loss of mechanical advantage. If it is too far out, it takes a very large movement of the steering system to change the position of the rudder.

The second adjustable feature is the need to tension the cable or line that is used to interconnect the components. Failure to tension this cable will cause a total steering failure. This can be done with a turnbuckle(s) or spring(s) as the most common methods.

Finally, until testing begins, the fore-aft position of the skipper is not known. If possible, don't fix the position of the steering "wheel" until some testing can be done and the optimum position of the skipper can be determined. This position is likely to be different for the Sprint and the Endurance. The position should be a comfortable one for the Endurance as it lasts for 90 minutes. **For the Sprint, it is highly likely that the skipper position should move forward. Some method that allows the skipper to move their weight forward should be considered.**

Once the design of the drive train begins, and once the position of the prop is determined, the rudder system can be designed and built. When doing this, be sure to consider the mounting for the boat sign base.

It can be seen in Picture 6 that at the slower endurance speeds, the appendage drag is minimal. But at sprint speeds of 25 knots or more, the drag becomes an unacceptable 13+% (i.e., 26 lbs) of the tow test drag. Rudder depth adjustments will be made between competitions in order to minimize this problem. The team may also manufacture a smaller aluminum rudder for use in the sprint race.

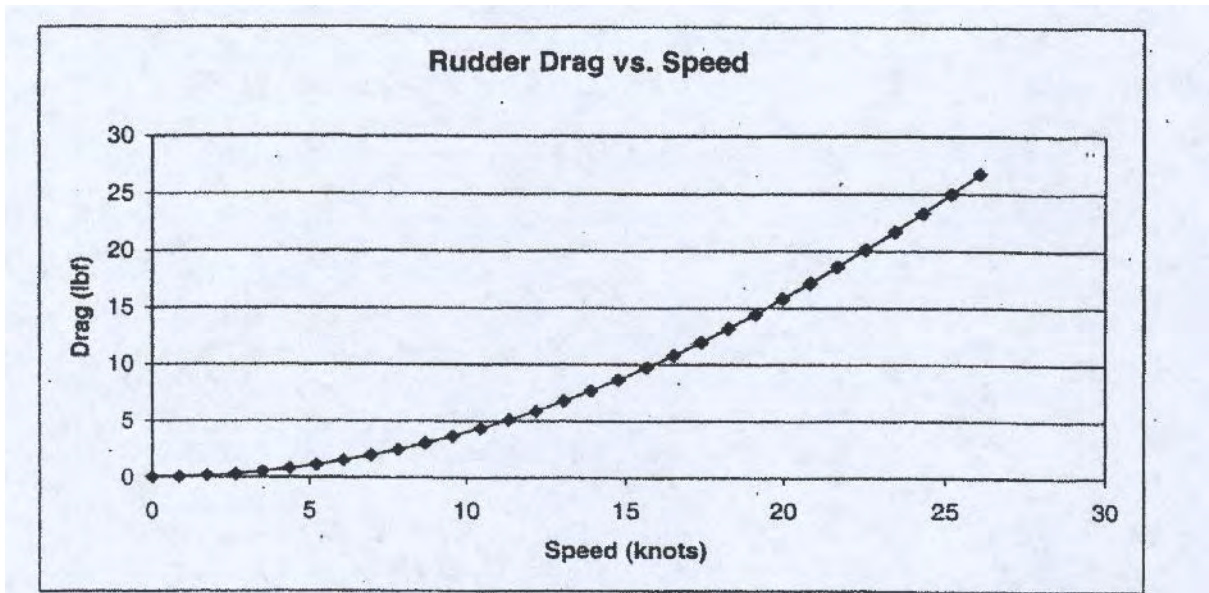

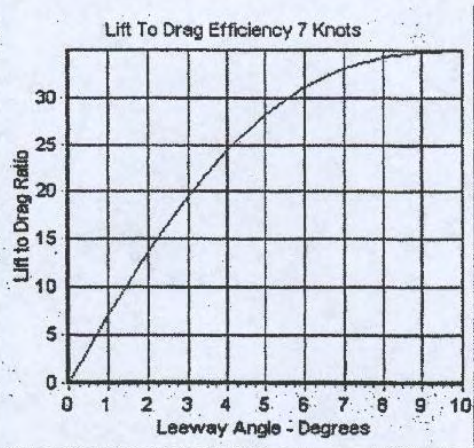
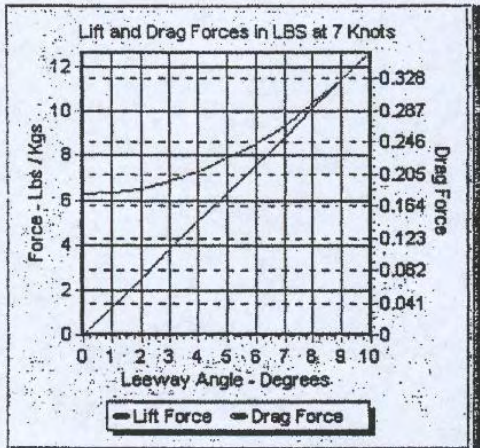
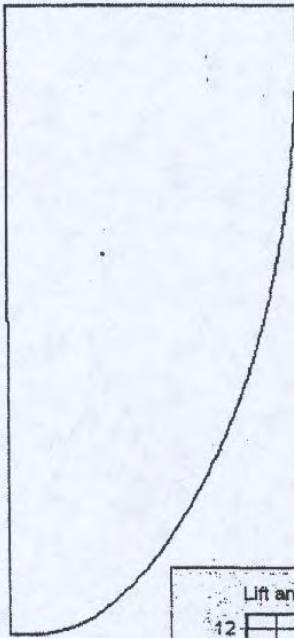

**Endurance Rudder at Expected Race Speed**

**Endurance Rudder**

<b>Endurance Rudder Dimensions (in)</b>	
Root Chord	5
Tip Chord	.5
Span	10
Aspect Ratio	5.58

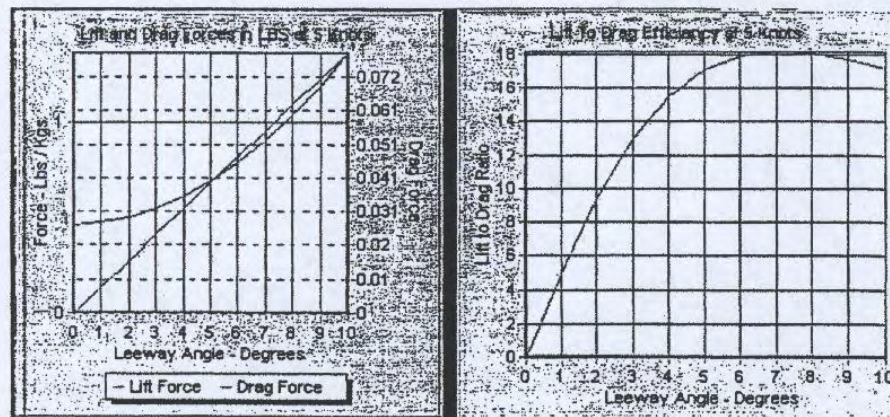
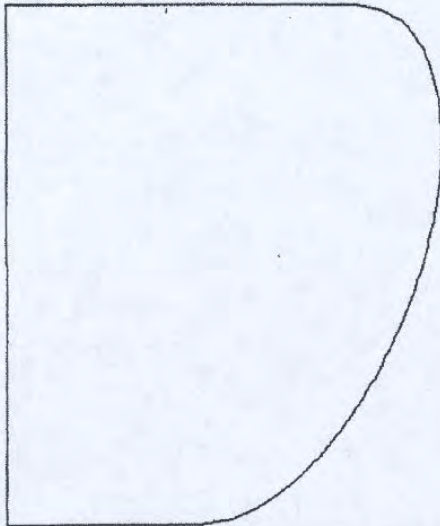

**Sprint Rudder**

<b>Sprint Rudder Dimensions (in)</b>	
Root Chord	2.25
Tip Chord	1.25
Span	3.5
Aspect Ratio	2.83

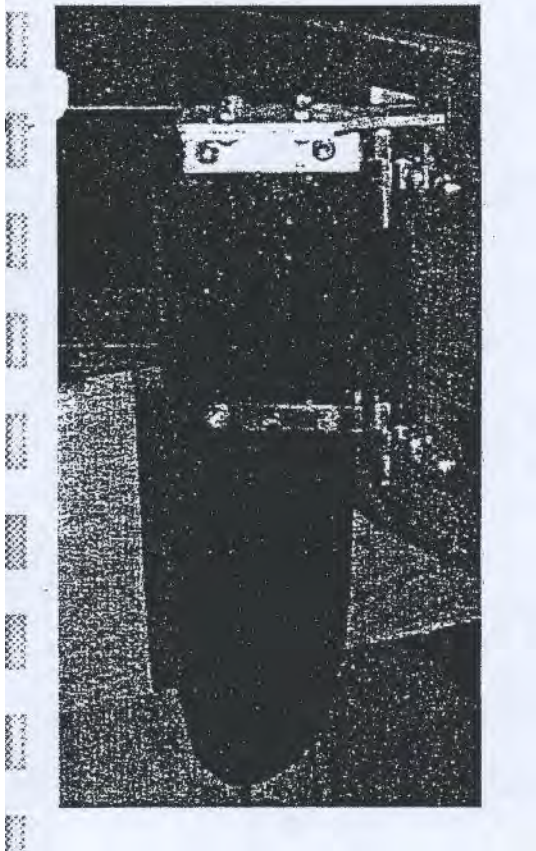

Rudder with Pintle and Gudgeon

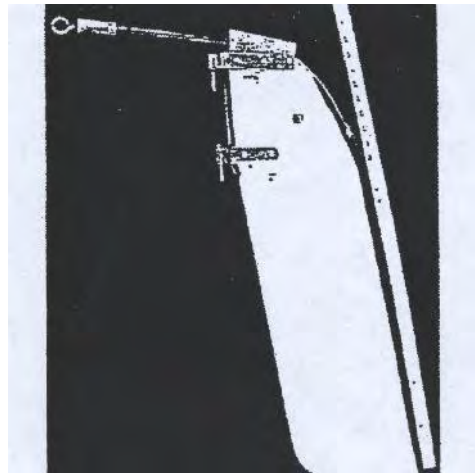

Alternate Rudder with Pintle & Gudgeon

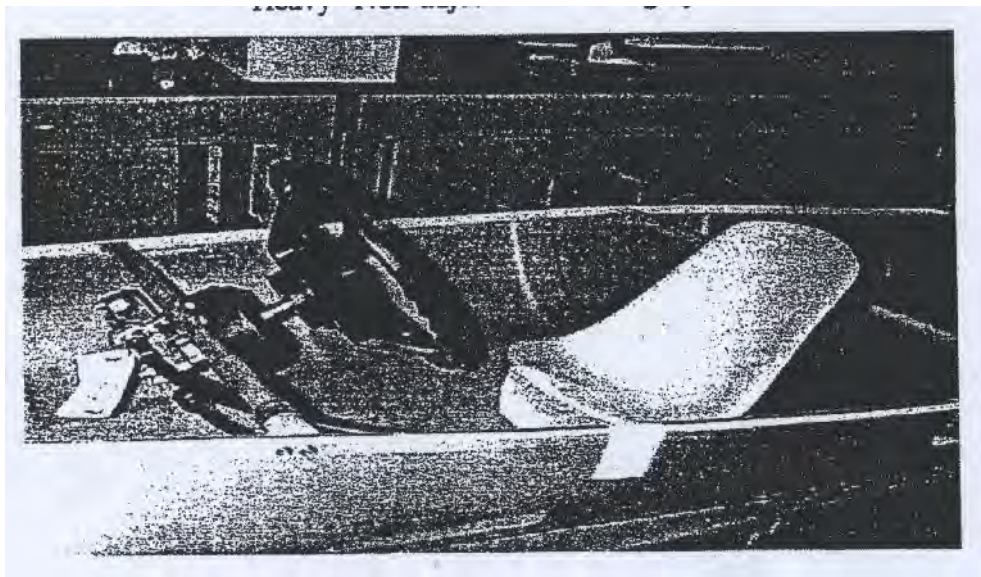

“Heavy” Non-adjustable Steering System

### 3.4 Steering System

The steering unit for this design is the rotary steering system. This unit is most desirable because it can provide the needed performance in a compact design. The steering gearbox has been secured to the aluminum tubular frame in front of the driver. The gearbox and steering column is position at the center. This component is bolted onto the tubular frame. The cable connecting the wheel to the outboard will run along the wall of the boat on the left side of the skipper. For this design the outboard lower unit is the rudder. Figure 6a and figure 6b below is a sketch and picture of the final steering system used. The rotary system is approximately \$ 200. The team was able to obtain this component at a discounted price of \$ 135.

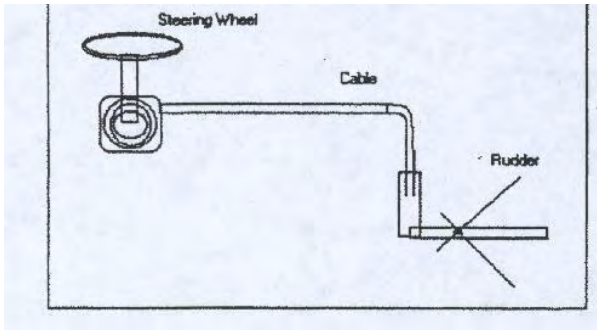

Figure 6a. Sketch of steering system used.

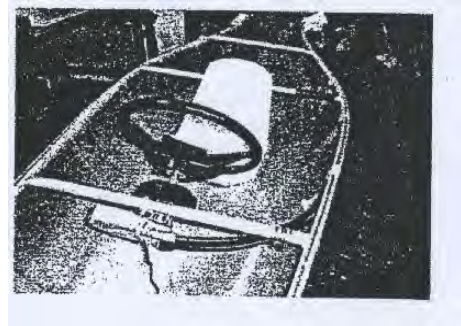
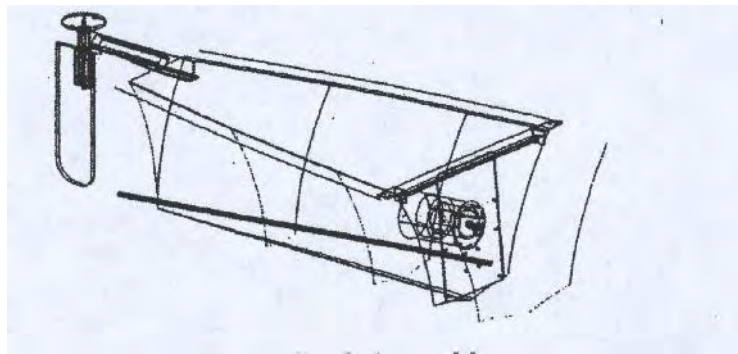

Figure 6b. Picture of steering unit.

## *Drive System*

The components of the drive system are the engine and drive shaft coupling, motor mount, thrust washer, drive shaft, pillow block, PVC tubing, bronze oil light bushings, grease seals, o-rings, and the propeller. The engine and drive shaft coupling consists of a gear on the motor shaft meshed to a gear on the drive shaft. The lower gear is secured to the shaft by a keyway and two setscrews. High strength spur gears are used in the sprint configuration to accommodate the high torque and horsepower. Cast iron spur gears are used for the endurance configuration since the horsepower is low. The largest spur gear, having a 9-inch diameter, is webbed to reduce unwanted weight. The reduction ratio between the motor and drive shaft for the sprint race and endurance race is 1.5:1 and 6:1, respectively. Along the drive shaft, a collared pillow block bearing is used to keep the shaft aligned and receive a portion of the propulsion force. Only one bearing was needed at the midpoint of the drive shaft due to the shaft's material type and length. The drive shaft is made of TGP (turned, ground, and polished) steel and is coupled with a tapered propeller shaft, which extends out the rear of the boat. The coupling is contained in 2-3/8" outside diameter PVC tubing. The inside diameter of the tubing is 2". The tubing contains grease seals, O-rings, and bronze oil light bushings to fit each shaft accordingly. Fiberglass is used to affix the PVC tubing to the hull of the boat.



Drive Shaft Assembly

The motor mount is made of 1/4-inch thick high-grade aluminum. It supports the motors and the drive shaft while allowing the gears to mesh properly. The motors are face-mounted to the plate. The motor mount is mounted perpendicular to the drive shaft. A thrust washer and thrust bearing ride against the block bearing which supports the drive shaft at the motor mount. The motor mount is fastened to the boat with a special bracket that consists of angle iron welded to special support plates on both ends and is supported at the bottom by two or more L-brackets on either side, which are affixed to the hull with fiberglass. In addition, the engine mount serves as a bulkhead, adding to the rigidity of the hull. A great attention to detail is used when mounting the bulkhead to ensure that it is secured at the same angle as the drive shaft. This detail eliminates the need for motor shims. The tapered propeller shaft is 13 1/2" long and the drive shaft is 5' 6" long. To achieve the maximum forward thrust force the drive shaft is placed at the smallest angle possible. The distance from the propeller to the motor mount plate and the diameter of the largest gear determined the angle of the drive shaft.

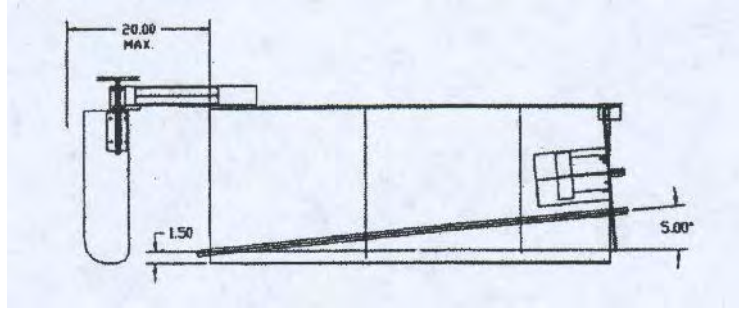

Drive Shaft Angle

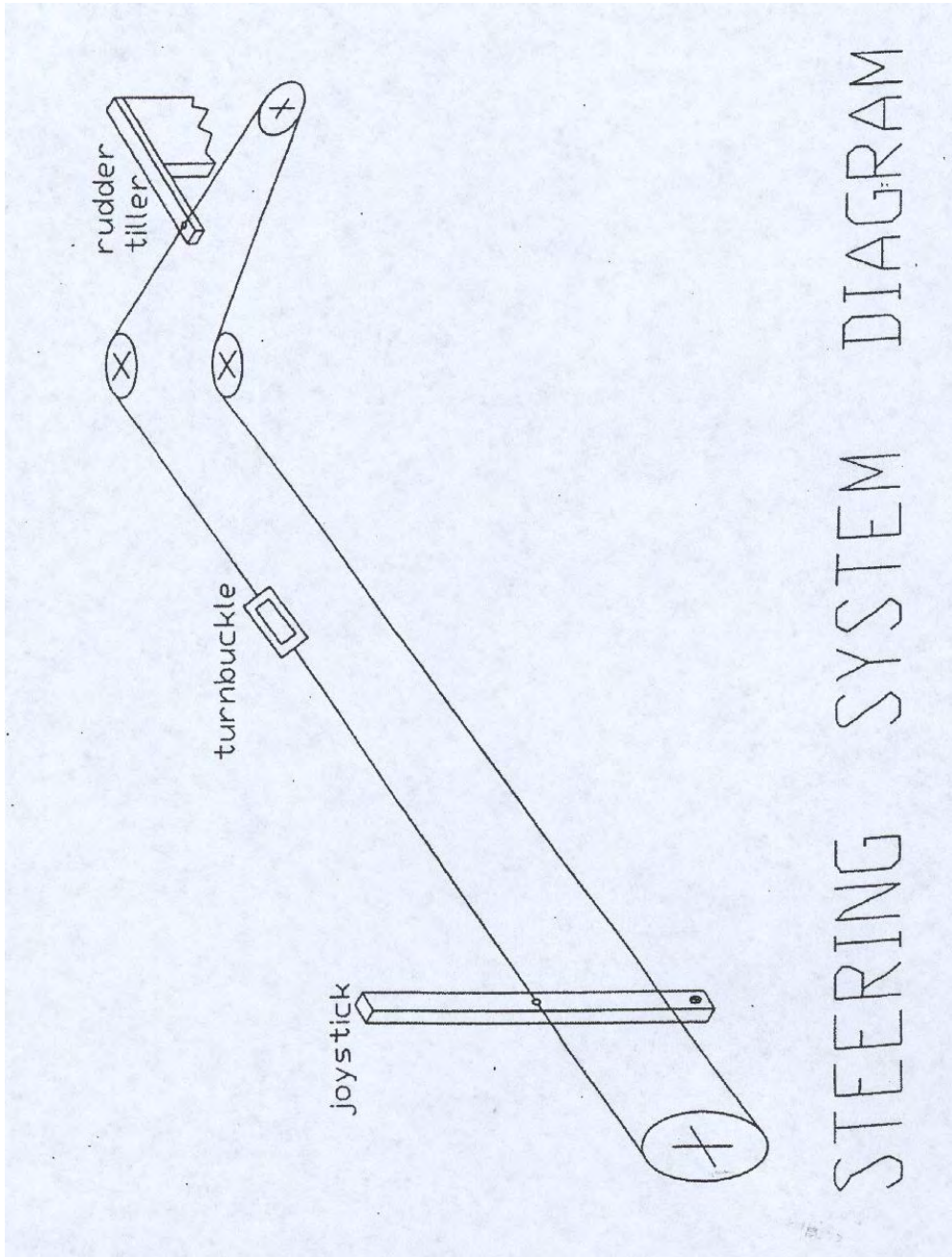

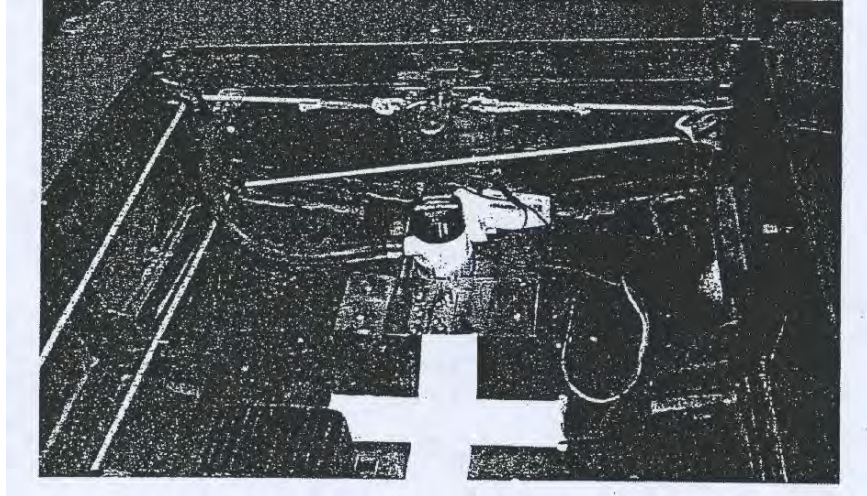

Steering Cables Attached to Rudder Tiller

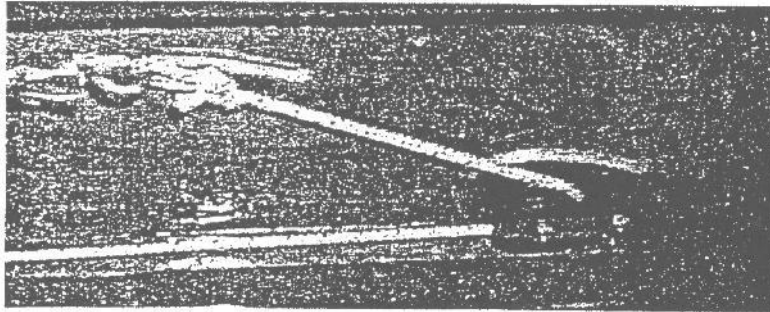

Steering Cables from Joystick

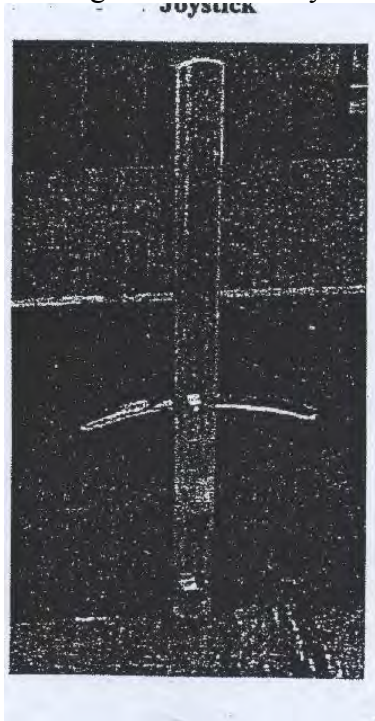

Joystick

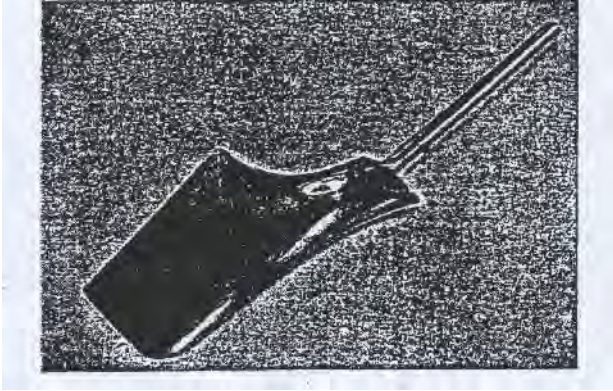

Rudder

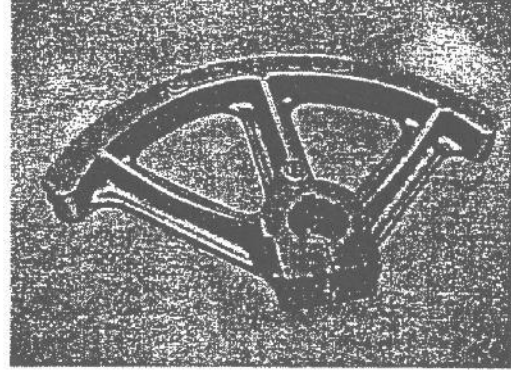

Quadrant

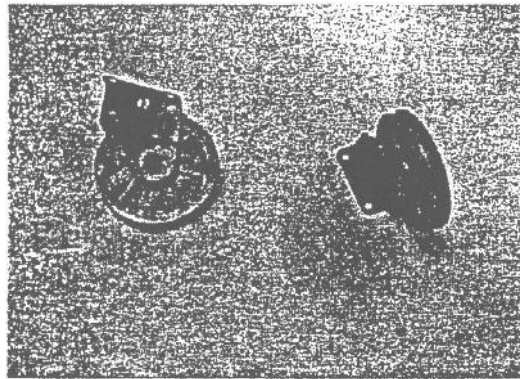

Pulleys

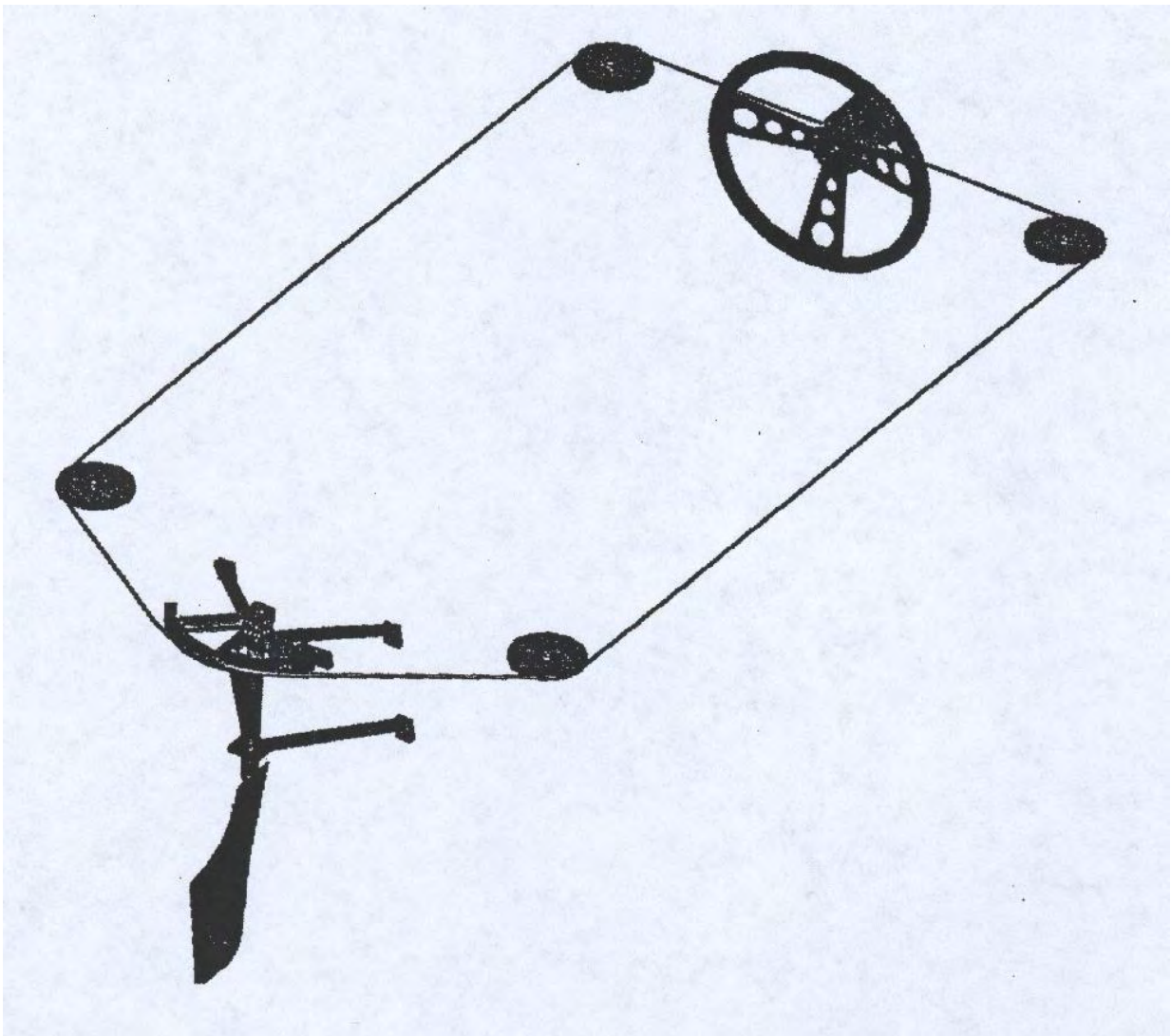

Glenwood Marine Equipment  
 1627 West El Segundo Blvd  
 Gardena, CA 90249  
 323-757-3141

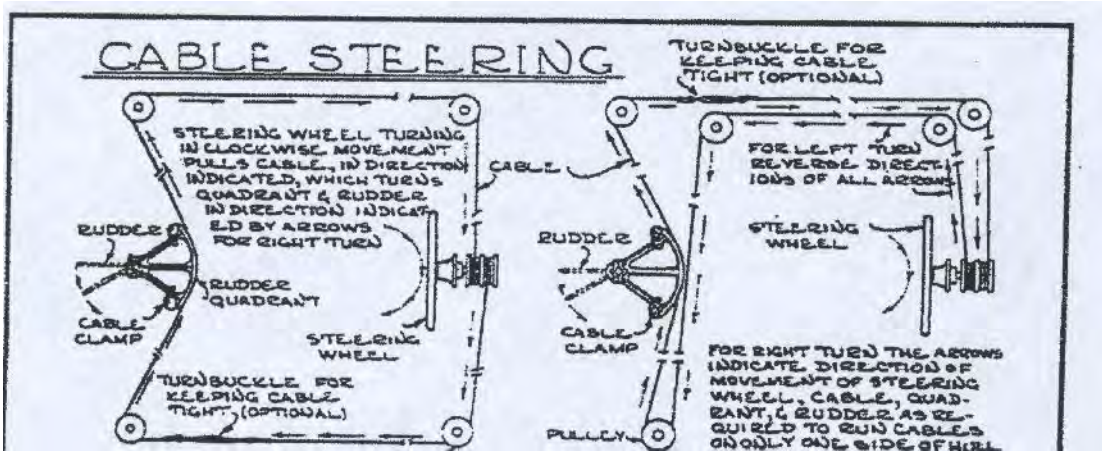

## Chapter 14—Launching

Each team will have an assigned space of 20' x 20' under a large tent. This is known as the "Paddock" area. It is your home away from home for the Event. Although you may have your boat on your sawhorses, it is highly desirable to have a "dolly" which serves as a stand and as a means of transporting the boat down to the water. Since the area is ' blacktop, it is easy to move the dolly and some find it desirable to make the dolly with a lower shelf to transport various heavy items.

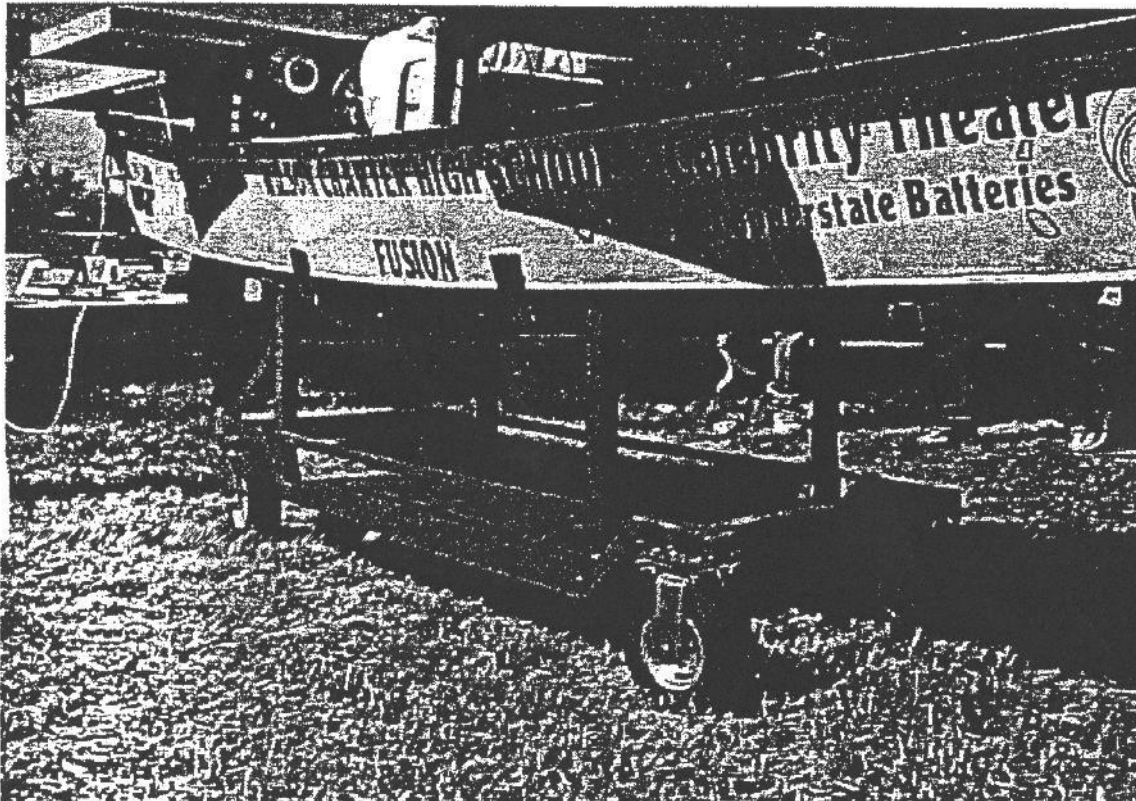

The tongue of the dolly has a removable handle and the front casters swivel while the back pair are fixed. It is important to remember that the weight it must carry at these times is likely to be upwards of 300 lbs. without any extra batteries, tools, whatever.

From the Paddock area, the boat is rolled into the "Staging Area" where it is re-inspected before each launching. Then it is on to the "On Deck" area for a final safety check. Typically, the boat can then be carried down the launch ramp and set in the water.



## Chapter 15—Power Management

The goal of the Endurance event is to travel as far as possible in the time allocated. Overall system efficiency is critical.

<b>Batteries &amp; Solar Panels</b>	<b>Motor Controller</b>	<b>Motor</b>	<b>Gears and Linkages</b>	<b>Propeller</b>
---	-----------------------------	--------------	-------------------------------	------------------

Figure 1. The major elements of a boat's drive system.

The overall efficiency of the drive system is the product of the efficiencies of the individual systems. The goal of the system design is to get as much of the power from the batteries and solar panels to the propeller to provide thrust for the boat.

For example, say that the batteries and solar panels combined provide 600 W of power. Assume that the motor controller efficiency is 95%, the motor is 85% efficient, the gears and linkage are 98% efficient, and the propeller is 75% efficient. How much power is available to the propeller? How much power does the propeller produce?

The total efficiency of the controller, motor, and gears/linkage is:

$$\text{Eff} = 0.95 * 0.85 * 0.98 = 0.791 \text{ or } 79.1 \% \text{ efficiency}$$

Therefore, the power available to the propeller is:

$$P = 600 \text{ W} * 0.791 = 475 \text{ W} \text{ (Power to the propeller)}$$

The power output of the propeller is:

$$P = 475 \text{ W} * 0.75 = 356 \text{ W} \text{ (Power from the propeller)}$$

So, an input power of 600 W results in only 356 W of power available for propulsion for the boat. This illustration shows the importance of the efficiency of each component involved in providing propulsion for the boat.

The first aspect of power or energy management is an efficient system. Once the system is designed and the boat is ready to compete, the second aspect of energy management is the use of the available power.

The energy from the solar panels is easy to deal with: use the energy as it is available. The energy from the batteries, however, is more complicated to manage. The energy in the battery should be consumed over the course of the Endurance competition. If the batteries are drained too quickly, the boat will be running on solar power only at the end of the competition. If the batteries are not drained by the end of the competition, then the boat did not travel as far as it could have.

**The goal of power management is to completely deplete the energy in the batteries over the course of the Endurance event.**

The chapter on Batteries shows that the higher the current drain on the batteries, the less total energy will be drawn from the batteries. It follows from this fact that way to draw the most energy from a battery in a fixed amount of time is to draw a constant current that will deplete the battery in the specified time of the event.

Drawing a constant current from the batteries sounds easy enough to do, but there is no readily available, off-the-shelf low voltage DC controller that will allow for constant current draw from the batteries. Most motor controllers deliver a constant voltage to the motor, which results in a fairly constant motor speed. This speed will vary with wind speed and direction, water conditions (waves), and boat drag (it takes more energy to turn the boat).

Given enough electronics expertise a constant current controller for the batteries could be designed and constructed, but this is not a simple task. A more practical approach to this problem would be to install a battery state-of-charge meter, as discussed in the Instrumentation chapter. Battery condition can be monitored and controlled by keeping track of the amp-hours consumed from the batteries.

Testing the batteries in advance to determine the amp-hour capacity is very important - do not rely on the manufacturer's specifications. As discussed in the Batteries chapter, the manufacturer's amp-hour rating, even if reliable, is valid only at the specific value of current used to generate the rating.

# Chapter 16—Instrumentation

Instrumentation in a solar-powered boat can be very simple or quite complicated. The term "instrumentation" will be used in this document to mean "any measurement device used to give information to the skipper." Instruments may include electrical meters that measure current, voltage, battery state of charge etc. There may also be devices that measure speed, temperature or motor rotational rate (rpm).

## Measuring Voltage

Voltage is measured using a voltmeter. The voltmeter is placed in parallel with the device whose voltage is to be measured. Figure 1 shows the proper connection for a voltmeter when used to measure the voltage across a battery.

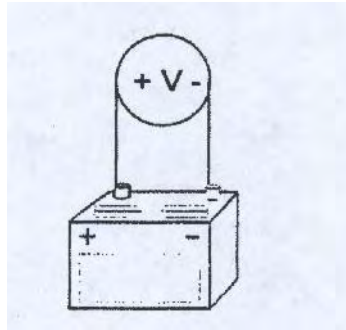

Figure 1. A voltmeter used to measure the voltage across a battery.

Voltmeters come in two basic types: analog or digital. Analog meters are usually powered by the circuitry whose voltage they are measuring. Digital meters usually require an external power source, so there may be more wiring involved. However, a more precise voltage reading can be obtained at a glance from a digital meter.

Many teams in the World Championship Solar Splash have used handheld digital multimeters that are hard-wired to the places where voltage measurements are desired. These meters have their own batteries to supply power.

## Measuring Current

Current is measured with an ammeter. You must be careful to NOT place an ammeter in parallel with a source, especially a battery. An ammeter has an internal resistance known as a shunt, which has a very low resistance value. If the ammeter is placed in parallel with a battery, a large amount of current will flow for a short period of time - either the fuse in the ammeter will burn up or the ammeter itself will burn up.

There are three basic ways to measure current

1. place an ammeter in series at the point in the circuit where the current measurement is desired
2. place an external shunt in series and measuring the voltage across the shunt
3. use a clamp-on ammeter

Method 1 is the least expensive method for measuring current Figure 2 shows a connection diagram for measuring current to the motor.

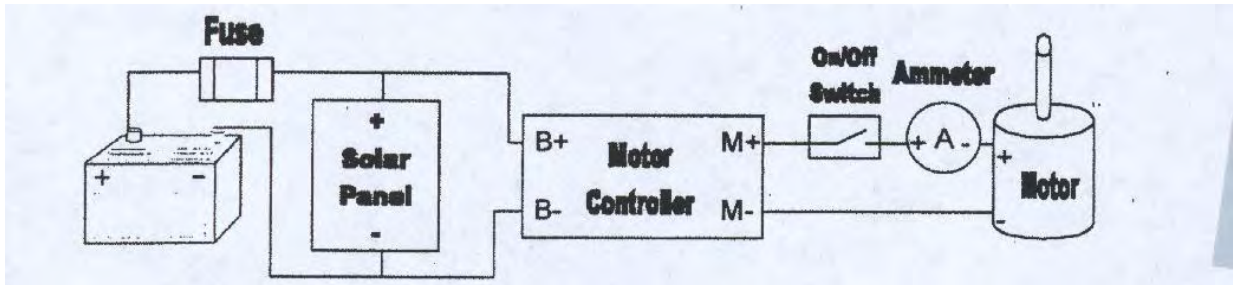

Figure 2. A basic wiring diagram for a solar boat with an ammeter for measuring motor current.

Measuring large currents often requires an external shunt or a clamp-on ammeter. An external shunt is a resistor whose value is known very precisely. The shunt is placed in series in a circuit just as the ammeter in Fig. 2 is. The voltage across the ammeter is measured, and the current passing through the ammeter can be calculated using Ohm's Law ( $I = V / R$ ). Shunt specifications are usually given as the maximum allowable current and the voltage across the shunt at that current.

For example, a shunt's rating is given as 50 mV (millivolts, or  $10^{-3}$  V) at 400 A. This means that if the voltage across the shunt is measured as 50 mV, then the current through the shunt is 400 A. If the voltage across the shunt is measured as 20 mV, then the current through the shunt is

$$I = (20 \text{ mV} / 50 \text{ mV}) * 400 \text{ A} = 160 \text{ A}$$

It is not necessary to know the resistance of the shunt if the current and voltage specifications are known. However, the resistance of this shunt can be calculated:

$$R = V / I = 50 \text{ mV} / 400 \text{ A} = 0.125 \text{ mohms, (the shunt resistance)}$$

Note that this is a very small resistance value and will have little effect on the circuit.

A clamp-on ammeter has the advantage of not requiring the circuit to be broken in order to measure current. A magnetic coil is clamped around a wire and the magnetic field measurement is converted into a current measurement. Clamp-on ammeters are more expensive than shunt-type ammeter. Additionally, DC clamp-on ammeters are far less common than AC clamp-on ammeters.

## Measuring Battery State of Charge

Determining a battery's state of charge by measuring the voltage across its terminals is not a very accurate method. The voltage across a battery depends on too many factors to make it a reliable indicator of the condition of the battery.

There are specialized meters that are designed for measuring a battery's state of charge. The E-Meter™ by Cruising Equipment Co., shown in Fig. 3, is an example of such a meter. These meters measure current, voltage and charge (amp-hours), and calculate various items of interest, such as time remaining and amp-hours used.

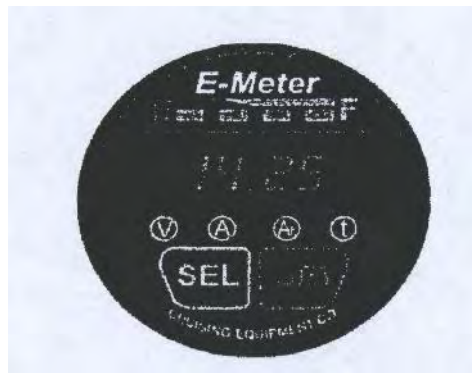

Figure 3. The E-Meter™ from Cruising Equipment Co. ([www.cruisingequip.com](http://www.cruisingequip.com))

Meters like the E-Meter require an external shunt and more complicated wiring than what is involved in wiring an ammeter or voltmeter. However, if a state-of-charge meter is installed properly the information it gives can be very useful in the Endurance event (see the chapter on Power Management).

How much instrumentation?

How many voltmeters and ammeters are needed? Is a state-of-charge meter necessary or just a cool thing to have? Is it important to know motor rpm or boat speed?

Let's start with the Sprint event. In the Sprint the goal is very simple: get to the finish line as fast as possible. It is not likely that you will deplete your batteries in the time it takes to run the Sprint. It is also not a good idea to be watching meters when your boat is traveling at high speed. For testing purposes, you may want to know how much current the motor is drawing, how fast the boat is going, or what the motor rpm is. But, in the actual event, knowing these things will probably not affect any decisions you make.

**If you are basing a decision on some parameter, then you should measure that parameter.**

**If you are not basing a decision on a particular parameter, then why complicate things by measuring that parameter?**

The Endurance event is a longer, more complicated event with slower speeds and more time *for* the skipper to make decisions. Therefore, more instrumentation is appropriate. If you are going to base decisions on the battery voltage level, then it would be appropriate to have a battery voltmeter. If you want to monitor the current from the solar panels, then place an ammeter in the solar panel circuit. But, unless you have some means of controlling the solar panel current, then you need to consider whether knowing the solar panel current is essential.

Keep in mind that too much instrumentation can be confusing and distracting. More instrumentation may be desirable while testing, but you may find that you don't need all of that information to make the necessary decisions during the actual event.

At a minimum you will probably want some means of determining your battery's state of charge. You will probably also want to know how much current you are drawing from the batteries at any time. Additional instrumentation can be added to the circuits fairly easily, but the positioning of the displays should be thought out carefully in the design of the skipper's "cockpit" area.

## Chapter 17—Strategies

It might seem as if the only event that requires a strategy is the Endurance but consider this: In at least two of the 9 years of the Splash, not completing the maneuverability course on the first run cost one or more schools the World Championship.

The very best and easiest strategy is to have enough practice with your boat to qualify in both configurations on the first try. Next, **do not have one skipper who can do it but be sure to have two.** You never know when you will need your backup.

Next, know the rules!! Not being familiar with all the rules could cost you precious time and avoid an unnecessary penalty.

The focus of this discussion will be on those elements to consider in running the Endurance Event. They include: available stored power, available real time solar energy, elapsed time, and how much energy is being consumed.

In a perfect world, you would like to be able to run the boat in the endurance configuration on batteries alone to see how long they will last under competition conditions. If they run out early, then you will have to reduce speed. Once this is measured or calculated (risky), it is best to use solar energy to increase your speed to whatever conditions exist. If you determine you can run for 90 minutes at XX amps, control the output of the batteries to that drain.

The riskier approach is to estimate what the weather conditions will be; hence, the amount of incoming solar energy. Combine that with the amount of stored energy and run the boat at the speed you think you can sustain.

The key thing to remember is that you don't want to finish with only half drained batteries but conversely, if you have to run on solar only for the last 20 minutes, you may be passed by many "turtles".

In summary, to optimize your overall score, do as well as you possibly can in all events.

Battery Current v Time

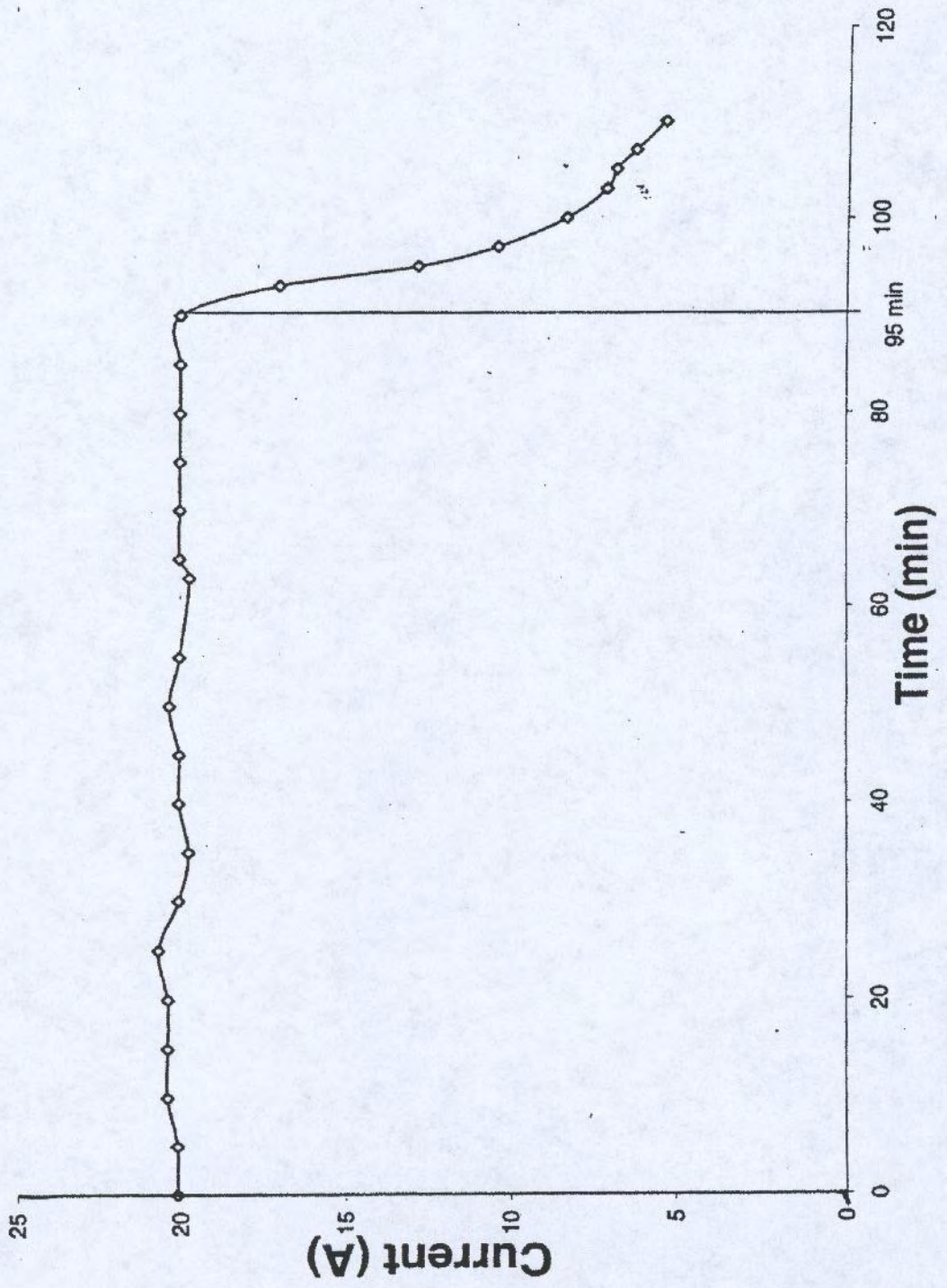

**Lessons Learned**  
**By a Faculty Advisor**  
**Competing in a *Solar Cup* Competition**

1. Familiarize yourself with the purchasing requirements for your school.
  - How much lead time do you need to pay for equipment and material required for the boat?
  - Do certain approved vendors by the District bind you?
  - Can you purchase materials and equipment and be reimbursed by your school?
  - Do you have to obtain bids for purchases?
2. Identify staff and student groups that can support your team's participation in the Metropolitan Water District's *Solar Cup*.
  - Does the computer lab have CAD software and capabilities for design ideas and improved technical report submissions?
  - Can you link your team's participation and help needed to the school's web page?
  - Does the school newspaper and/or yearbook staff have contacts in the business community?
  - Can students working on the team receive any type of elective credit and/or school time to complete this project?
  - What resources can you obtain from both certified and classified staff at the school to help in the areas of electrical design; mechanical design; availability of power and hand tools; facility to work on and store the boat and equipment?
3. Communicate, communicate, communicate!
  - Identify those things your team will be involved in and advise your administrator in the beginning of the project.
  - This includes students who may need training in how to use certain power and hand tools for working on the boat
  - When and where you will be testing this boat in the water with students.
  - Will students be interviewed by the media and are they prepared?
  - Communicate to parents of team members about the project and the commitment that will be required of team members.
  - Let parents know the team's work schedule including after school hours, weekends, and holidays.
  - Make a list of things you may need help with including, but not limited to, financial support for non-boat related items, transportation, food, equipment, specialty expertise, i.e. (electrical, welding, mechanical, communication equipment, etc.).
4. Communicate with you local water district member sponsor.
5. Communicate when necessary with Metropolitan Water District.

## **My Top 10 Do's**

1. Remember the KISS Principle “Keep it simple stupid”.
2. Empower student team members!
3. Make a plan for all aspects of the project!
4. TEST, TEST, TEST!!!
5. Read the rules and workshop manual!
6. Meet frequently!
7. Communicate frequently with the MWD Tech Team
8. Use all the resources you community has!
9. Include anyone with an interest and dedication!
10. Take Pride in what you build and present

## Chapter 18—Technical Reports

Two reports, each worth 25 points, must be submitted to the Metropolitan Water District during the Solar Cup program. This chapter outlines the rubric used for grading these reports and the timeline listing the due dates. Use these as guides to assist you in formatting your reports.

The primary goal of a report is to convey technical concepts as clearly as possible. This will require both clear diction and appropriately labeled figures. A common problem in technical reports is the inaccurate depiction of the true shape and size of the hull or other components. We suggest using and referencing material provided in the Technical Manual and workshops to insure the accuracy of the hull and component characteristics. The physical dimensions (length, height, width) of relevant components should be included in relation to the hull.

Innovative designs are wonderful and we strongly encourage them as long as they conform to the Solar Cup rules. Please keep in mind that your overall success in the Solar Cup event will depend more on the *reliability* of your design. You are encouraged to discuss the reliability of your design within each report.

Quality designed systems are based on theoretical calculations and experimental evidence. Even simple calculations provide enormous insight into a design problem. Report scoring is heavily weighted in favor of discussion of evidence and calculations.

All reports should be original bodies of work written by student team members. Students are expected to amass and reference material from a variety of sources in order to synthesize a report in their own voice. Reports from veteran teams will be compared to submissions from previous years. **Report scoring is heavily weighted to discourage plagiarism.**

You will receive feedback in writing after submitting each report. Consider it carefully! If you don't understand or if you want to verify that you do, please don't hesitate to contact Metropolitan with questions.

## **PLAGIARISM**

The basic rule is this: If you include material drawn from any source beyond your own firsthand experience, and if this material is not common knowledge of the kind possessed by everyone working in the general area, you must give credit for that material in a reference that identifies the source by author, date, title and page (or, if the source is not something in print, by details about the source that are equally precise).

Specifically:

- If you quote directly from your source, you must enclose the quoted material, even if it is no more than a phrase or a single word, within quotation marks, and provide a reference.
- If you paraphrase--that is, restate the material in your own words--(a) the paraphrasing must represent a substantial change from the original, not just the changing of occasional words and phrases, and (b) you must provide a reference.
- If you present material that is common knowledge, but borrow someone else's organizational pattern, you must acknowledge that use in a reference.
- If the language and organization are your own, you must still acknowledge any ideas or information that are not common knowledge in a reference.

Whenever you are in doubt whether to acknowledge borrowing, a good rule is to ask yourself: Could a reader who consulted the books and articles listed in my bibliography recognize in my paper sentences, phrases, words, patterns of organization, interpretations, points of view, ideas or facts as deriving from one of these sources?

If you can, you must cite the source of such passages and use quotation marks where needed. Any clear parallel between your paper and its sources which a reader would discover if he/she consulted your sources should have already been indicated through your references.

**Source:** Occidental College, STUDENT HANDBOOK, 2003-2004, p. 53

## **Solar Cup 2020**

### **Technical Report Details**

**Reports will only be accepted electronically.** All reports are due to Royetta S. Perry at Metropolitan Headquarters by 5:00 p.m. of the due date. If your report is larger than 10 mbyte, then you may have trouble emailing it. If you have a large file, please contact Royetta S. Perry at [rperry@mwdh2o.com](mailto:rperry@mwdh2o.com) for instruction on uploading it via Hightail.

- Reports should be at least 2000 words in length (five to ten pages minimum) not including figures, tables, a bibliography and reference materials.
- You are strongly encouraged to employ a Technical Writing Style that formally and clearly conveys your ideas.
- Technical reports must be written by students with support from teachers and mentors.
- Plagiarism is to be avoided and references should be properly cited.
- Reports should include a Title Page, Table of Contents, List of Figures, Introduction, Body of Report, Conclusion, Bibliography, and Appendices for reference material.
- Figures should be numbered, titled and labeled with an appropriate caption.

## **Drive Train/Steering Report is due January 9, 2020**

This report should include a narrative and design diagram detailing your proposed Drive Train/Steering system. Use calculations and/or measurements to discuss how components impact the center of mass and center of buoyancy of your craft. Be sure to include the following mechanical components in both the diagram and narrative:

- A top/bottom and side view of the drive train with the outline of the hull and bulkhead shown.
- Information on the angle of the drive shaft and the consequential angles of the stuffing box and strut.
- Necessary text to accompany the diagram. The text needs to identify components such as the motor(s), drive shaft, etc.
- The information should be detailed enough so we understand your approach.
- A complete list of the required items will be given out at the report writing workshop on 11/23.

**Steering portion:** Experience has shown that although steering may be the simplest system in the boat, it often does not get the attention that is needed. Include depictions of side and top/bottom views of the steering system in your report. Text should include information about the components. A drawing of the rudder(s), which includes dimensions, is necessary.

Drive Train/Steering will be worth 25 points. Veteran team reports will be compared to team's previous report submissions and graded original content based on the following criteria:

- **Punctuality (3pts.)**
- **Introduction (3pts.):** Title Page, Team Advisor, Team Members, Contact Info, Table of Contents
- **Methodology (5pts.):** Design Considerations, Problem Solving, Organizational Strategy
- **Supporting Technical Material (5pts.):** Tables, Schematics, Block Diagrams, Data, Graphs, Illustrations, Calculations
- **Conclusions/Summaries (5pts.):** Critical Analysis, Data Interpretation
- **Grammar and Clarity (4pts.):** Neatness, Legibility, Brevity, Spelling, Attributions

## **Electrical/Solar Report is due February 13, 2020**

This report should include a narrative and design diagram detailing your proposed electrical system and solar array. Use calculations and/or measurements to discuss the power, current, and voltage of the electrical components. Be sure to include an introduction on the physics of photovoltaics and the following electrical components in both the diagram and narrative (including component manufacturer, rated voltage and rated wattage):

- Batteries , Solar Panels, Motors, Motor Controller, Bilge Pump
- Dead-man switch, 350 Amp fuse, Wire size
- Drawings that show the relative position of the solar panels on the hull from a top view and a side view.
- Your solar panel/hull attachment technique must be shown. (There is a requirement in the rules that the panels must be mechanically attached to the hull. *Velcro is not an adequate solution.*)
- A complete list of the required items will be given out at the report writing workshop on 2/1/2020.

Electrical/Solar reports will be worth 25 points. Veteran team reports will be compared to team's previous report submissions and graded original content based on the following criteria:

- **Punctuality (3pts.)**
- **Introduction (3pts.):** Title Page, Team Advisor, Team Members, Contact Info, Table of Contents
- **Methodology (5pts.):** Design Considerations, Problem Solving, Organizational Strategy
- **Supporting Technical Material (5pts.):** Tables, Schematics, Block Diagrams, Data, Graphs, Illustrations, Calculations
- **Conclusions/Summaries (5pts.):** Critical Analysis, Data Interpretation
- **Grammar and Clarity (4pts.):** Neatness, Legibility, Brevity, Spelling, Attributions
- **Grammar and Clarity (4pts.):** Neatness, Legibility, Brevity, Spelling, Attributions

Criteria	<b>DRIVETRAIN/STEERING &amp; ELECTRICAL/SOLAR RUBRIC</b>			
<b>Punctuality</b>	<b>3 Points</b> – Report is submitted on-time	<b>1 Point</b> – Report is late due to extenuating circumstances office contacted before due date/time.	<b>0 Points</b> – Report is late no contact made before due date/time.	
<b>Introduction</b>	<b>3 Points</b> – Report includes <b>detailed introductory information</b> , Report contents well presented and very helpful to the reader.	<b>1 Point</b> - Report provides <b>adequate introductory information</b> . Report contents adequately presented and useful to the reader.	<b>0 Points</b> - Writer <b>provides little</b> if any introduction information. Report contents not well presented to significantly aid reader.	
<b>Methodology</b>	<b>5-4 Points</b> - Report provides detailed information regarding design considerations and methodology. Evidence of significant and reasonably comprehensive literature research/review included.	<b>3 Points</b> - Report provides adequate information regarding design considerations and methodology. Evidence of literature review/research included.	<b>2 Points</b> - Report provides some information regarding design considerations and methodology. Little evidence of literature review/research included.	<b>1 Point</b> - Report provides minimal or no information regarding design considerations and methodology. No evidence of literature review/research included.
<b>Supporting Technical Material</b>	<b>5 Points</b> – Technical material detailed and accurate. Diagrams, calculations, illustrations, graphs/tables add significantly to the reader's understanding. Significant contribution of material generated by team.	<b>4 Points</b> – Technical material accurate and adds to the reader's understanding of the topic. Some material generated by team.	<b>3-2 Points</b> - Technical material generally accurate and sometimes add to the reader's understanding. Little or no material generated by team.	<b>1 Point</b> - Diagrams are not accurate OR do not add significantly to the reader's understanding. No material generated by team.
<b>Conclusions/ Summaries</b>	<b>5 Points</b> – Significant evidence of sound data analysis. Conclusions data driven, well constructed and succinct.	<b>4 Points</b> - Evidence of good data analysis. Conclusions well constructed and succinct.	<b>3-2 Points</b> - Some evidence of data analysis. Conclusions somewhat well constructed.	<b>1 Point</b> – Little or no evidence of data analysis. Minimal or poorly drawn conclusions.
<b>Grammar and Clarity</b>	<b>4 Points</b> – None or inconsequential grammatical or spelling errors. Appropriate attributions of data sources. Writing generally clear and concise.	<b>2 Point</b> - Some grammatical or spelling errors. Appropriate attributions of data sources. Writing generally clear and concise somewhat verbose.	<b>0 Points</b> - Many grammatical or spelling errors. Incomplete or no attributions of data sources. Writing unclear and difficult to read.	

